

# Tooling Solutions





# On The Mark. We're Standing Behind It.

Since 1924, BURNDY has been at the forefront of technological innovation. BURNDY tooling delivers a key component in creating a conforming electrical connection while providing users an ergonomic and reliable design with safe crimping and cutting capabilities.

In fact, our products come with the assurance of the BURNDY® Engineered System. Our coordinating dies, connectors and tools are designed to work together to meet the highest conformance standards in the electrical industry.

When improving our products or debuting new ones, we're committed to ensuring they continue to work with the BURNDY pieces you already have. And with our world-class tool support, training and customer service, help is always at your fingertips.



Connecting Power to Your World™



## TABLE OF CONTENTS

Introduction 7

### Crimpers — Battery Actuated



PAT46LWS-LI	9
PAT46LW-LI	10
PAT750-LI	11
PAT644-LI	12
PAT81KFT-LI	13
PAT4PC834-LI	14
PAT600-LI	15
PAT500SJ-LI	16
PATMD6-LI	17
PATMD6LIWCJ	18
PATMDLICUTKIT1	19
PATMD1022-LI	20

### Crimpers — Self-Contained Hydraulic



Y750HSXT	21
Y35	22
Y39	23
Y644HSXT	24
Y81KFT	25
Y4PC834	26
Y500CT-HS	27

### Crimpers — Remote Hydraulic



Y60LW	28
Y60BHU	29
Y46LWSBH	30
Y46LWBH	31
Y45	32
Y750BHXT	33
Y35BH	34
Y39BH	35
Y644MBH	36
Y81KFTMBH	37
Y4PC834MBH	38
Y34BH	39
Y29BH	40

**Crimpers — Mechanical & Ratchet**



Y10D	41
Y10-22	41
YF22-10FL	42
YF-TOOL Series	43
Y8MRB-1	44
MR8 Series	45
Y10MRSA1	46
MRE10-22 Series	47
MR Series	48
MR4C	49
Y1MRTC	50
Y122CMR	51
M8ND	52
MRC840 Series	53
MY28 / MY29 Series	54
OH25	55
OUR840	56
MD6 Series	57
MD7 Series	58
MD7-34R	59



**Crimpers — OEM**

OEM840NCP	60
Y6NCP1	61
Y6NCP1SD	62
Y46OEM12T	63
Y46OEM11T	64
Y29NC	65



**Dies, Die Kits**

12-Ton U Dies	66
U Die Kit Series	67
W Dies	68
W Die Kit Series	69



**Cutters — Battery Actuated**



PATCUT2156-LI	70
PATHCC10-18V	71
PATCUT129-LI	72
PATCUT245-LI	73
PATMDCUT-LI	74
PATMD-LLI Series	75
BCC1000CUAL	76

**Cutters — Self-Contained Hydraulic**

YCUT129ACSR	77
-------------	----



**Cutters — Remote Hydraulic**

RHCC4CUAL	78
RHCC10 Series	79
RHCC129ACSR	80
RHCC245CUAL	81

**Cutters — Mechanical & Ratchet**



MCC Series	82
RCC Cu/Al Type	83
RCC Cu/Al & ACSR Type	84
RWRC916	85

**Hydraulic Pumps**



Y10AC9	86
EPP10	87
EP10	88
EPAC10	89
HP10	90
FP10	90
GP10	91

**Hydraulic Hoses; Pump Accessories**



Hydraulic Hoses	92-93
Pump Accessories	94



**Accessories**

W Die Related	95
MD6 / MD7 Related	96
Miscellaneous Accessories	97



**Gauges**

FORCEGAUGE12-15	98
PT29279-2	98
WIREMIKE	99

Adjustable Ratchet Torque Tools	100
---------------------------------	-----



**Auger Bits**

Design Selection	101
Part Number Chart	102



**Low Pressure Hydraulic**

HIW716ENF Impact Wrench	103
HIW716MAG Impact Wrench	104
LPHY750XT Crimper	105
HBR Series Breakers	106
Submersible Pumps	107
HPT-R1 Series Tampers	108
HHS Series Hand and Pole Saws	109
HPS-LW Series Pole Saws	110
HPP Series Power Packs	111
Low Pressure Hydraulic Accessories	112



**Knockout Sets**

Mechanical & Ratchet	113
Self-Contained Hydraulic	114
Hydraulic with Pump	115



**Benders**

Hand Banders	116
Electric Benders	117



<b>Wire Management - The SmartCart®</b>	
<b>2-Wheel Heavy Duty Cart</b>	<b>118</b>
<b>2-Wheel Light Duty Cart</b>	<b>119</b>
<b>Wall Wire Reel Storage System</b>	<b>120</b>
<b>Expanded Cable Range Information</b>	
<b>4-POINT® Series</b>	<b>121-122</b>
<b>Y644 Series</b>	<b>123</b>
<b>Die Index Reference</b>	<b>124-134</b>
<b>Index (Alpha-Numeric)</b>	<b>135-141</b>





## Introduction

### Installation Tools

The BURNDY® Engineered System features the most complete line of installation tools in the electrical industry. Available in various styles: battery actuated, mechanical, full cycle ratchet, self contained hydraulic, remote controlled hydraulic, along with power actuated pumps, hoses and accessories. BURNDY has the options to suit your needs. BURNDY tools are designed to integrate with the complete line of BURNDY connectors. Whether you're a small contractor working with #22 wire or a large utility working with 2500 kcmil conductor, there is a BURNDY tool available to do the job.

The benefits of the BURNDY® Engineered System are many, however, probably the most significant benefit is reliability. There is nothing more important to the electrical industry today than reliability. It represents the one area that leads to economical installations that will endure for the life of the installation.

### Tool Center

An important element of the BURNDY® Engineered System is the BURNDY Tool Center, located at 150 Burndy Road, Littleton, NH 03561 (800-426-8720 or 603-621-4499). This center provides advice and information on the operation, maintenance and repair of BURNDY tools. The repair center is staffed with specialized technicians who provide the best possible service for all BURNDY tools, pumps and accessories.

BURNDY designed and produced the first self contained hydraulic compression electrical connector installation tool in 1934. In our continuing efforts to provide the highest quality and highest value connection systems, we offer the current BURNDY tool policy.

### Limited Warranty

The majority of BURNDY tools are warranted to be free of defects in materials and workmanship for a period of five (5) years from the date of shipment. See specific tool page for length of warranty. If inspection by a certified technician shows the trouble is caused by defective workmanship or material, BURNDY will repair or (at our option) replace the tool.

#### This Warranty does not apply where:

- Repairs or alterations have been made or attempted by others
- Repairs are required because of normal wear and tear
- The tool has been abused, misused or improperly maintained
- The use of any non-BURNDY product has resulted in damage to the tool

### Repair Policy

All non-warranty repaired tools are completely reconditioned and receive a limited 1-year warranty. Non-warranty repair returns tools to like-new condition at a maximum cost of 40% of a new tool. A nominal service charge of \$5 is applied to all repairs to cover shop supplies, oil disposal and other miscellaneous services not covered as part of the standard repair.

If the decision is made not to repair, a handling charge of \$25.00 will be applied plus return freight costs.

### Return Procedure

All tools sent to the BURNDY Tool Center or an authorized repair center must be accompanied by a purchase order with detailed bill to and ship to address authorizing repair. Requests for repair charges before work is done must be stated on the purchase order. All tools sent to the BURNDY Tool Center or an authorized repair center as a warranty claim must be accompanied by a proof of purchase such as a BURNDY invoice or invoice from any BURNDY distributor.

All tools must be shipped at the owner's expense, prepaid. BURNDY pays for the return freight, same surface freight as received. Airfreight returns will be returned same way collect for non-warranty repair and prepaid for warranty repairs.

This warranty and repair policy supercedes all previous policies and is in effect as of January 1, 2005.



**PAT46LWS-LI****15-Ton, Scoop Style C-Head**  
Hydraulic Self-Contained, 18V Lithium-Ion

- 2" jaw opening
- Used with P dies; U dies with PUADP-1 adapter (sold separately)
- Scoop style C-head with 355° head rotation
- Overmolded, ergonomic handle
- Improved ergonomic balance
- Includes 2 batteries, charger, and polymer carrying case

**For Use On:****Copper - #8 AWG Str. - 1500 kcmil**

Code Cable, Navy Cable, Flexible, Extra Flexible  
1/2" - 1" Ground Rods

**Terminals, grounding:**

to 500 kcmil; YGA, YGHA, YGF

**Terminals, uninsulated:**

#8 - 1500 kcmil; YA, YA-2N, YA-L, YA-LB, YA-TC,  
YA-2LN, YAB-4N, YAV-L, YAV-RS, YA-TC-FX

**Terminals, insulated:**

#8 - 2/0; YAEV-L, YAEV-H, YAEV-RS, YAEV-RH

**Splices:**

#8 - 1500 kcmil; YS, YS-T, YS-L, YS-LB, YST,  
YSP-T, YGS, YGHS

**Taps:**

#14 - 1000 kcmil; YH, YCHC  
to 4/0 AWG; YC-C

**Taps, grounding:**

to 500 kcmil; YGHC-C, YGHP-C, YGHR-C

**Aluminum - #8 AWG - 1250 kcmil**

Code Cables

**Terminals:** YA-A, AYP, AYPO

**Splices:** YS-A, YS-AT, YRB

**Taps:** YFD, YFN, YFO, YFR

**ACSR** - see Overhead Transmission & Distribution  
Sections of the BURNDY® Master Catalog

**Specifications:**

<b>Output Force:</b>	15 Tons
<b>Tool Weight:</b>	19.1 lbs
<b>Size:</b>	18.00" x 14.00" x 3.00"
<b>Die Style:</b>	P and U style (with PUADP-1)
<b>Jaw Opening:</b>	2.00"
<b>Operating Voltage:</b>	18 V-DC Lithium-Ion
<b>Recharge Time:</b>	30 minutes
<b>Warranty:</b>	5 year limited warranty Lifetime warranty on INFINITY DRIVE® 1 year on batteries and charger

**Accessories:**

<b>P15K:</b>	Cutter Die, max. diameter 1.2"
<b>PUADP-1:</b>	U Die Adapter
<b>BAT18VLI:</b>	Hi-capacity Li-Ion (3.0 AH)
<b>PATCHGR-LI:</b>	120V-AC Charger
<b>PATCHGR-LIDC:</b>	12/24V-DC Charger

**Variations:**

**PAT46CLWS-LI** PAT46LWS-LI with rubber covered head

Ni-MH platform is also available:

**PAT46LWS-18V** Ni-MH battery version

**PAT46CLWS-18V** PAT46LWS-18V (Ni-MH) with rubber covered head

# Tooling

## Crimpers — Battery Actuated



### PAT46LW-LI

#### 15-Ton, Lightweight Latch Head

Hydraulic Self-Contained, 18V Lithium-Ion

- 2" jaw opening
- Used with P dies; U dies with PUADP-1 adapter (sold separately)
- Latch-head, Light weight
- 355° head rotation
- Ergonomically balanced
- Includes 2 batteries, charger, and polymer carrying case

#### For Use On:

##### Copper - #8 AWG Str. - 1500 kcmil

Code Cable, Navy Cable, Flexible, Extra Flexible  
1/2" - 1" Ground Rods

##### Terminals, grounding:

to 500 kcmil; YGA, YGHA, YGF

##### Terminals, uninsulated:

#8 - 1500 kcmil; YA, YA-2N, YA-L, YA-LB, YA-TC,  
YA-2LN, YAB-4N, YAV-L, YAV-RS, YA-TC-FX

##### Terminals, insulated:

#8 - 2/0; YAEV-L, YAEV-H, YAEV-RS, YAEV-RH

##### Splices:

#8 - 1500 kcmil; YS, YS-T, YS-L, YS-LB, YST,  
YSP-T, YGS, YGHS

##### Taps:

#14 - 1000 kcmil; YH, YCHC  
to 4/0 AWG; YC-C

##### Taps, grounding:

to 500 kcmil; YGHC-C, YGHP-C, YGHR-C

##### Aluminum - #8 AWG - 1250 kcmil

Code Cables

**Terminals:** YA-A, AYP, AYPO

**Splices:** YS-A, YS-AT, YRB

**Taps:** YFD, YFN, YFO, YFR

**ACSR** - see Overhead Transmission & Distribution

Sections of the BURNDY® Master Catalog



#### Specifications:

<b>Output Force:</b>	15 Tons
<b>Tool Weight:</b>	16.8 lbs
<b>Size:</b>	18.75" x 13.75" x 3.75"
<b>Die Style:</b>	P and U style (with PUADP-1)
<b>Jaw Opening:</b>	2.00"
<b>Operating Voltage:</b>	18 V-DC Lithium-Ion
<b>Recharge Time:</b>	30 minutes
<b>Warranty:</b>	5 year limited warranty Lifetime warranty on INFINITY DRIVE® 1 year on batteries and charger

#### Accessories:

<b>P15K:</b>	Cutter Die, max. diameter 1.2"
<b>PUADP-1:</b>	U Die Adapter
<b>BAT18VLI:</b>	Hi-capacity Li-Ion (3.0 AH)
<b>PATCHGR-LI:</b>	120V-AC Charger
<b>PATCHGR-LIDC:</b>	12/24V-DC Charger
<b>PT208620:</b>	Lanyard

#### Variations:

Ni-MH platform is also available:  
**PAT46LW-18V** Ni-MH battery version

# PAT750-LI

## 12-Ton, C-Head

Hydraulic Self-Contained, 18V Lithium-Ion

- 1.65" jaw opening
- Used with U dies
- C-head with 355° head rotation
- Bearing/alignment guide for HYGROUND® as well as other asymmetrical connectors
- Includes 2 batteries, charger, and polymer carrying case

### For Use On:

#### Tension Sleeves

Copper	#8 sol. - 500 kcmil
Aluminum	#8 sol. - 587.2 kcmil
ACSR	#4 - 556.5 kcmil

#### Taps

Copper	#14 sol. - 500 kcmil
Aluminum	#8 - 500 kcmil

#### Aerial Cable

Copper	#6 - 500 kcmil
--------	----------------

#### Terminals & Splices

Copper	#8 - 750 kcmil
Aluminum	#8 - 750 kcmil
ACSR	#4 - 556 kcmil

#### HYGROUND® (Compression Grounding)

Copper	#8 - 500 kcmil
Ground Rods	1/2" - 1" diameter



*Wide U-dies (sold separately) can be used with long barrel terminals and splices saving time and labor!*



### Specifications:

<b>Output Force:</b>	12 Tons
<b>Tool Weight:</b>	15.7 lbs
<b>Size:</b>	15.75" x 13.50" x 3.50"
<b>Die Style:</b>	U style
<b>Jaw Opening:</b>	1.65"
<b>Operating Voltage:</b>	18 V-DC Lithium-Ion
<b>Recharge Time:</b>	30 minutes
<b>Warranty:</b>	5 year limited warranty Lifetime warranty on INFINITY DRIVE® 1 year on batteries and charger

### Accessories:

<b>BAT18VLI:</b>	Hi-capacity LI battery (3.0 AH)
<b>PATCHGR-LI:</b>	120V-AC Charger
<b>PATCHGR-LIDC:</b>	12/24V-DC Charger
<b>PT208620:</b>	Lanyard

### Variations:

<b>PAT750C-LI</b>	PAT750LI with rubber covered head
<b>PAT750K-LI</b>	PAT750LI with KEARNEY™ style head used with KEARNEY™ WH1 and WH2 and BURNDY U dies with KUADP adapter (sold separately)
Ni-MH platform is also available:	
<b>PAT750XT-18V</b>	Ni-MH battery version
<b>PAT750CXT-18V</b>	PAT750XT-18V (Ni-MH) with rubber covered head

# Tooling

## Crimpers — Battery Actuated



# PAT644-LI

## 11-Ton, Latch Head

Hydraulic Self-Contained, 18V Lithium-Ion

- Dieless system
- Range taking capabilities
- 355° head rotation
- Ergonomically balanced
- Includes 2 batteries, charger, and polymer carrying case

### For Use On:

Copper #6 -1000 kcmil

**Terminals:** YA-L, YA-2LN, YA, YA-2N, YA-L-2TC, YAB-4N, YA-L-TC, YA-2L, YA-4N

**Splices:** YS-L, YS, YS-T

Aluminum #6 - 750 kcmil

**Terminals:** YA-A, YA-A-TN

**Splices:** YS-A

**HYPLUG™:** AYP, AYPO

*See Expanded Range details in Reference Section*



**PAT644XT-18V**  
(Ni-MH version)  
in case



### Specifications:

<b>Output Force:</b>	11 Tons
<b>Tool Weight:</b>	16.3 lbs
<b>Size:</b>	15.62" x 14.12" x 3.25"
<b>Die Style:</b>	Dieless
<b>Operating Voltage:</b>	18 V-DC Lithium-Ion
<b>Recharge Time:</b>	30 minutes
<b>Warranty:</b>	5 year limited warranty Lifetime warranty on INFINITY DRIVE® 1 year on batteries and charger

### Accessories:

<b>BAT18VLI:</b>	Hi-capacity LI battery (3.0 AH)
<b>PATCHGR-LI:</b>	120V-AC Charger
<b>PATCHGR-LIDC:</b>	12/24V-DC Charger
<b>PT208620:</b>	Lanyard

### Variations:

Ni-MH platform is also available:  
**PAT644XT-18V** Ni-MH battery version

US: 1-800-346-4175 / International: 1-603-647-5299 / Canada: 1-800-387-6487 / [www.burndy.com](http://www.burndy.com)

# PAT81KFT-LI

## 6-Ton, 4-POINT® Dieless Latch Head Hydraulic Self-Contained, 18V Lithium-Ion

- Dieless system
- Range taking capabilities
- 360° head rotation
- Mechanical ram release (no battery consumption)
- Includes 2 batteries, charger, and polymer carrying case

### For Use On:

Copper #8 -1000 kcmil

**Terminals:** YA, YA-L  
**Splices:** YS-L, YS, YS-T, Y-R

Copper Flex #8 - 777.7 kcmil Flex (750 Nominal)

**Terminals:** YA-FX, YAV, YA-L-FX  
**Splices:** YS, YSV-FXB

Aluminum #8 - 750 kcmil

**Terminals:** YA-A, YA-A-TN  
**Splices:** YS-A  
**HYPLUG™:** AYP, AYPO

*See Expanded Range details in Reference Section*



**PAT81KFT-18V**  
(Ni-MH version)  
in case



### Specifications:

<b>Output Force:</b>	6 Tons
<b>Tool Weight:</b>	13.2 lbs
<b>Size:</b>	15.62" x 14.12" x 3.25"
<b>Die Style:</b>	Dieless
<b>Operating Voltage:</b>	18 V-DC Lithium-Ion
<b>Recharge Time:</b>	30 minutes
<b>Warranty:</b>	5 year limited warranty Lifetime warranty on INFINITY DRIVE® 1 year on batteries and charger

### Accessories:

<b>BAT18VLI:</b>	Hi-capacity LI battery (3.0 AH)
<b>PATCHGR-LI:</b>	120V-AC Charger
<b>PATCHGR-LIDC:</b>	12/24V-DC Charger
<b>PT208620:</b>	Lanyard

### Variations:

Ni-MH platform is also available:  
**PAT81KFT-18V** Ni-MH battery version

# Tooling

## Crimpers — Battery Actuated



### PAT4PC834-LI

#### 6-Ton, 4-POINT® Dieless, C-Head Hydraulic Self-Contained, 18V Lithium-Ion

- Dieless system
- Range taking capabilities
- 360° head rotation
- Ergonomically balanced
- Includes 2 batteries, charger, and polymer carrying case

#### For Use On:

Copper #8 -1000 kcmil

**Terminals:** YA, YA-L

**Splices:** YS-L, YS, YS-T, Y-R

Copper Flex #8 - 777.7 kcmil Flex (750 Nominal)

**Terminals:** YA-FX, YAV, YA-L-FX

**Splices:** YS, YSV-FXB

Aluminum #8 - 750 kcmil

**Terminals:** YA-A, YA-A-TN

**Splices:** YS-A

**HYPLUG™:** AYP, AYPO

*See Expanded Range details in Reference Section*



#### Specifications:

<b>Output Force:</b>	6 Tons
<b>Tool Weight:</b>	13.0 lbs
<b>Size:</b>	15.62" x 14.12" x 3.25"
<b>Die Style:</b>	Dieless
<b>Operating Voltage:</b>	18 V-DC Lithium-Ion
<b>Recharge Time:</b>	30 minutes
<b>Warranty:</b>	5 year limited warranty Lifetime warranty on INFINITY DRIVE® 1 year on batteries and charger

#### Accessories:

<b>BAT18VLI:</b>	Hi-capacity LI battery (3.0 AH)
<b>PATCHGR-LI:</b>	120V-AC Charger
<b>PATCHGR-LIDC:</b>	12/24V-DC Charger
<b>PT208620:</b>	Lanyard

#### Variations:

Ni-MH platform is also available:  
**PAT4PC834-18V** Ni-MH battery version



# PAT600-LI

## 6-Ton, Latch Head

Hydraulic Self-Contained, 18V Lithium-Ion

- Permanent functional D3 groove (no die needed)
- Uses W, X, W-VT style dies
- 180° head rotation
- Enhanced clearance for tap connections
- Includes 2 batteries, charger, and polymer carrying case

### For Use On:

Copper #8 - 600 kcmil

**Terminals:** YA, YA-L

**Splices:** YS-L, YS, YS-T, Y-R

Copper Flex #8 - 350 kcmil Flex

**Terminals:** YA-FX, YAV, YA-L-FX

**Splices:** YS, YSV-FXB

Aluminum #8 - 350 kcmil

**Terminals:** YA-A, YA-A-TN

**Splices:** YS-A

### Variations:

**PAT600C-LI** PAT600-LI with rubber covered head

Ni-MH platform is also available:

**PAT600-18V** Ni-MH battery version

**PAT600C-18V** PAT600-18V (Ni-MH) with rubber covered head



### Specifications:

<b>Output Force:</b>	6 Tons
<b>Tool Weight:</b>	10.1 lbs
<b>Size:</b>	14.50" x 13.75" x 3.50"
<b>Die Style:</b>	W, V, W-VT style dies
<b>Operating Voltage:</b>	18 V-DC Lithium-Ion
<b>Recharge Time:</b>	30 minutes
<b>Warranty:</b>	5 year limited warranty Lifetime warranty on INFINITY DRIVE <sup>®</sup> 1 year on batteries and charger

### Accessories:

<b>BAT18VLI:</b>	Hi-capacity LI battery (3.0 AH)
<b>PATCHGR-LI:</b>	120V-AC Charger
<b>PATCHGR-LIDC:</b>	12/24V-DC Charger
<b>WDIETREE:</b>	W die holder
<b>PT208620:</b>	Lanyard

# Tooling

## Crimpers — Battery Actuated



### PAT500SJ-LI

#### 6-Ton, Scissor Action

Hydraulic Self-Contained, 18V Lithium-Ion

- Interchangeable scissor action crimping and cutting jaws
- 180° head rotation
- Uses W and X style dies
- Ergonomically balanced tool design
- Includes 2 batteries, charger, and polymer carrying case

#### For Use On:

Copper, Aluminum, ACSR, Steel, Copperweld, Alumoweld, 6201, 5005, Compressed, and Compact Conductors

#### Taps:

Copper: #10 sol. to 2/0 str.

Aluminum & ACSR: #14 sol. to 4/0 ACSR

#### Stirrups:

#6 to 4/0 ACSR

#### Overhead Full Tension Deadends, Full Tension Splices and Terminals:

#10 str. to 4/0 ACSR

#### Installs Splices, Taps or Terminations:

#8 to 500 kcmil Copper Stranded (YA, YA-L, YS, YS-L)

#8 to 350 kcmil Copper Flex

#8 to 350 kcmil Aluminum (YA-A, YS-A)

#### Variations:

<b>PAT500SJ6-LI</b>	BG and D3 grooves
<b>PAT500SJ68-LI</b>	O and D3 grooves
<b>PAT500SJ66-LI</b>	D3 groove only (snub-nose)
<b>PAT500SJ6K-LI</b>	KEARNEY™ groove (snub-nose) [Accepts KEARNEY™ dies; BURNDY W and X dies with KWADP adapter, sold separately]



#### Specifications:

<b>Output Force:</b>	6 Tons
<b>Tool Weight:</b>	11.5 lbs
<b>Size:</b>	17.00" X 14.25" X 3.00"
<b>Die Style:</b>	W and X (with crimping jaws)
<b>Operating Voltage:</b>	18 V-DC Lithium-Ion
<b>Recharge Time:</b>	30 minutes
<b>Warranty:</b>	5 year limited warranty Lifetime warranty on INFINITY DRIVE® 1 year on batteries and charger

#### Accessories:

<b>BAT18VLI:</b>	Hi-capacity LI battery (3.0 AH)
<b>PATCHGR-LI:</b>	120V-AC Charger
<b>PATCHGR-LIDC:</b>	12/24V-DC Charger
<b>W28K:</b>	Cutter Dies (cuts 4-4/0 Cu, Al, ACSR)
<b>PATMD6JC:</b>	Jaw covers for PATMD6 and PATMD6-8 versions
<b>PATMD6-6JC:</b>	Jaw covers for PATMD6-6 snub-nose versions
<b>PATMD6-KJC:</b>	Jaw covers for PATMD6-K snub-nose versions
<b>PT10074020:</b>	Wrist strap
<b>WDIETREE:</b>	W-die holder for 6 die sets

#### Interchangeable Jaw Assemblies:

<b>PATJAWSMD6</b>	BG and D3 grooves
<b>PATJAWSMD6-8</b>	O and D3 grooves
<b>PATJAWSMD6-6</b>	D3 groove only (snub-nose)
<b>PATJAWSMD6K</b>	KEARNEY™ groove (snub-nose)
<b>PATJAWSCUT</b>	Cutter jaw set

US: 1-800-346-4175 / International: 1-603-647-5299 / Canada: 1-800-387-6487 / [www.burndy.com](http://www.burndy.com)

# PATMD6-LI

## 6-Ton, IN-LINE®, Scissor Action

Hydraulic Self-Contained, 18V Lithium-Ion

- Interchangeable scissor action crimping and cutting jaws
- 350° head rotation
- Uses W and X style dies
- Ergonomically balanced tool design
- Includes 2 batteries, charger, and polymer carrying case

### For Use On:

Copper, Aluminum, ACSR, Steel, Copperweld, Alumoweld, 6201, 5005, Compressed, and Compact Conductors

### Taps:

Copper: #10 sol. to 2/0 str.

Aluminum & ACSR: #14 sol. to 4/0 ACSR

### Stirrups:

#6 to 4/0 ACSR

### Overhead Full Tension Deadends, Full Tension Splices and Terminals:

#10 str. to 4/0 ACSR

### Installs Splices, Taps or Terminations:

#8 to 500 kcmil Copper Stranded (YA, YA-L, YS, YS-L)

#8 to 350 kcmil Copper Flex

#8 to 350 kcmil Aluminum (YA-A, YS-A)

### Variations:

<b>PATMD6-LI:</b>	BG and D3 grooves
<b>PATMD6-8-LI:</b>	O and D3 grooves
<b>PATMD6-6-LI:</b>	D3 groove only (snub-nose)
<b>PATMD6-K-LI:</b>	KEARNEY™ groove (snub-nose)
	[Accepts KEARNEY™ dies; BURNDY W and X dies with KWADP adapter, sold separately]

Ni-MH platform is also available:

<b>PATMD6-14V:</b>	BG and D3 grooves
<b>PATMD6-8-14V:</b>	O and D3 grooves
<b>PATMD6-6-14V:</b>	D3 groove only (snub-nose)
<b>PATMD6-K-14V:</b>	KEARNEY™ groove (snub-nose)

**Crimp/Cut Kits are also available supplied with both crimping and cutting jaws**



### Specifications:

<b>Output Force:</b>	6 Tons
<b>Tool Weight:</b>	7.8 lbs
<b>Size:</b>	21.00" x 5.50" x 3.75"
<b>Die Style:</b>	W and X (with crimping jaws)
<b>Operating Voltage:</b>	18 V-DC Lithium-Ion
<b>Recharge Time:</b>	30 minutes
<b>Warranty:</b>	5 year limited warranty Lifetime warranty on INFINITY DRIVE® 1 year on batteries and charger

### Accessories:

<b>BAT18VLI:</b>	Hi-capacity LI battery (3.0 AH)
<b>PATCHGR-LI:</b>	120V-AC Charger
<b>PATCHGR-LIDC:</b>	12/24V-DC Charger
<b>W28K:</b>	Cutter Dies (cuts 4-4/0 Cu, Al, ACSR)
<b>PATMD6JC:</b>	Jaw covers for PATMD6 and PATMD6-8 versions
<b>PATMD6-6JC:</b>	Jaw covers for PATMD6-6 snub-nose versions
<b>PATMD6-KJC:</b>	Jaw covers for PATMD6-K snub-nose versions
<b>TOOLBAGMDLI:</b>	Tool bag
<b>PT10074020:</b>	Wrist strap
<b>WDIETREE:</b>	W-die holder for 6 die sets

### Interchangeable Jaw Assemblies:

<b>PATJAWSMD6</b>	BG and D3 grooves
<b>PATJAWSMD6-8</b>	O and D3 grooves
<b>PATJAWSMD6-6</b>	D3 groove only (snub-nose)
<b>PATJAWSMD6K</b>	KEARNEY™ groove (snub-nose)
<b>PATJAWSCUT</b>	Cutter jaw set

**US: 1-800-346-4175 / International: 1-603-647-5299 / Canada: 1-800-387-6487 / www.burndy.com**

# Tooling

## Crimpers — Battery Actuated



### PATMD6LIWCJ

## 6-Ton, IN-LINE<sup>®</sup>, Scissor Action

Hydraulic Self-Contained, 18V Lithium-Ion

- Interchangeable scissor action crimping and cutting jaws included
- 350° head rotation
- Actuated blade guide (with cutting jaws)
- Kit includes tool, crimping jaw, cutting jaw, 2 batteries, charger, and soft carrying case

### For Use On:

#### Crimping:

Copper, Aluminum, ACSR, Steel, Copperweld, Alumoweld, 6201, 5005, Compressed, and Compact Conductors

#### Taps:

Copper: #10 sol. to 2/0 str.

Aluminum & ACSR: #14 sol. to 4/0 ACSR

#### Stirrups:

#6 to 4/0 ACSR

#### Overhead Full Tension Deadends, Full Tension Splices and Terminals:

#10 str. to 4/0 ACSR

#### Installs Splices, Taps or Terminations:

#8 to 500 kcmil Copper Stranded (YA, YA-L, YS, YS-L)

#8 to 350 kcmil Copper Flex

#8 to 350 kcmil Aluminum (YA-A, YS-A)

### Cutting Capacity (Maximum):

#### ACSR:

556 kcmil (26/7 Dove)

#### AAC:

636 kcmil

#### Copper:

500 kcmil soft drawn copper

#### Guy Wire:

3/8" Utility and High Strength

(Not for use on Extra High Strength Conductor)



### Specifications:

Output Force:	6 Tons
Tool Weight:	7.8 lbs
Size:	21.00" x 5.50" x 3.75"
Die Style:	W and X (with crimping jaws)
Operating Voltage:	18 V-DC Lithium-Ion
Recharge Time:	30 minutes
Warranty:	5 year limited warranty Lifetime warranty on INFINITY DRIVE <sup>®</sup> 1 year on batteries and charger

### Variations:

PATMD6LIWCJ	BG & D3 Grooves, soft case
PATMD68LIWCJ	O & D3 Grooves, soft case
PATMD66LIWCJ	D3 Groove only (Snub-nose), soft case
PATMD6KLIWCJ	KEARNEY <sup>™</sup> (Snub-nose), hard case

### Accessories:

BAT18VLI:	Hi-capacity LI battery (3.0 AH)
PATCHGR-LI:	120V-AC Charger
PATCHGR-LIDC:	12/24V-DC Charger
PATMD6JC:	Jaw covers for PATMD6 and PATMD6-8 versions
PATMD6-6JC:	Jaw covers for PATMD6-6 snub-nose versions
PATMD6-KJC:	Jaw covers for PATMD6-K snub-nose versions
W28K:	Cutter Dies (cuts 4-4/0 Cu, Al, ACSR)
WDIETREE:	W die holder for 6 sets (sold separately)
TOOLBAGMDLI:	Replacement Tool Bag
PT10074020:	Wrist Strap

US: 1-800-346-4175 / International: 1-603-647-5299 / Canada: 1-800-387-6487 / [www.burndy.com](http://www.burndy.com)

**PATMDLICUTKIT1****6-Ton, IN-LINE<sup>®</sup>, Scissor Action**  
Hydraulic Self-Contained, 18V Lithium-Ion

- Interchangeable scissor action crimping and cutting jaws included
- 350° head rotation
- Actuated blade guide (with cutting jaws)
- Kit includes tool, crimping jaw, cutting jaw, 2 batteries, charger, and hard plastic carrying case

**For Use On:****Crimping:**

Copper, Aluminum, ACSR, Steel, Copperweld, Alumoweld, 6201, 5005, Compressed, and Compact Conductors

**Taps:**

Copper: #10 sol. to 2/0 str.

Aluminum & ACSR: #14 sol. to 4/0 ACSR

**Stirrups:**

#6 to 4/0 ACSR

**Overhead Full Tension Deadends, Full Tension Splices and Terminals:**

#10 str. to 4/0 ACSR

**Installs Splices, Taps or Terminations:**

#8 to 500 kcmil Copper Stranded (YA, YA-L, YS, YS-L)

#8 to 350 kcmil Copper Flex

#8 to 350 kcmil Aluminum (YA-A, YS-A)

**Cutting Capacity (Maximum):****ACSR:**

556 kcmil (26/7 Dove)

**AAC:**

636 kcmil

**Copper:**

500 kcmil soft drawn copper

**Guy Wire:**

3/8" Utility and High Strength

(Not for use on Extra High Strength Conductor)

**Specifications:**

<b>Output Force:</b>	6 Tons
<b>Tool Weight:</b>	7.8 lbs
<b>Size:</b>	21.00" x 5.50" x 3.75"
<b>Die Style:</b>	W and X (with crimping jaws)
<b>Operating Voltage:</b>	18 V-DC Lithium-Ion
<b>Recharge Time:</b>	30 minutes
<b>Warranty:</b>	5 year limited warranty Lifetime warranty on INFINITY DRIVE <sup>®</sup> 1 year on batteries and charger

**Variations:**

<b>PATMD6LICUTKIT1</b>	BG & D3 Grooves, hard case
<b>PATMD68LICUTKIT1</b>	O & D3 Grooves, hard case
<b>PATMD66LICUTKIT1</b>	D3 Groove only (Snub-nose), hard case
<b>PATMD6KLICUTKIT1</b>	KEARNEY™ (Snub-nose), hard case

**Accessories:**

<b>BAT18VLI:</b>	Hi-capacity LI battery (3.0 AH)
<b>PATCHGR-LI:</b>	120V-AC Charger
<b>PATCHGR-LIDC:</b>	12/24V-DC Charger
<b>PATMD6JC:</b>	Jaw covers for PATMD6 and PATMD6-8 versions
<b>PATMD6-6JC:</b>	Jaw covers for PATMD6-6 snub-nose versions
<b>PATMD6-KJC:</b>	Jaw covers for PATMD6-K snub-nose versions
<b>W28K:</b>	Cutter Dies (cuts 4-4/0 Cu, Al, ACSR)
<b>WDIETREE:</b>	W die holder for 6 sets (sold separately)
<b>PT50025151:</b>	Replacement Hard Carrying Case
<b>PT10074020:</b>	Wrist Strap

# Tooling

## Crimpers — Battery Actuated



### PATMD1022-LI

#### Battery Tool to crimp #22-#10 AWG Uninsulated (bare), Vinyl, and Nylon Insulated Connectors

- Includes two die sets to accommodate nylon, vinyl and uninsulated terminals and splices from #22 - #10 AWG
- Easy groove identification with color coded dies
- Includes 2 batteries, charger, and polymer carrying case

#### For Use On:

##### Using BECBSD Die Set:

###### #22 - #10 AWG Uninsulated (Bare) Terminals/Splices

Types: T, YAD, T-F, YAD-F, YAV, YAV-H, YAV-R, YAV-T-F, YAV-H-F, YAV-Z, YSV, YSV-H

##### Using BECNVSD Die Set:

###### #22 - #10 AWG Nylon & Vinyl Insulated Terminal/Splices

Types: TP, BA, TP-F, BA-EF, TP-Z, BA-EZ, TP-LF, BA-EL, SP, BS, TN, YAES, TN-F, YAES-F, SNM\*, YSES\*, YAE-N, YAE-N-F, YAE-Z, YSE-HN, YSE-H, YAEV

\*Excludes #10 size



#### Specifications:

Output Force:	3.2 Tons
Tool Weight:	5.1 lbs
Size:	15.25" x 5.00" x 3.00"
Die Style:	SD Industry-Standard Die Envelope
Operating Voltage:	18 V-DC Lithium-Ion
Recharge Time:	15 minutes
Warranty:	2 year limited warranty Lifetime warranty on INFINITY DRIVE® 1 year on batteries and charger

#### Accessories:

PG-403-2R	Die Inspection Gauge for #22 - #14 AWG
PG-403-1R	Die Inspection Gauge for #12 - #10 AWG
PG-406-1:	Die Inspection Gauge for #22 - #18 AWG (Red)
PG-407-1:	Die Inspection Gauge for #16 - #14 AWG (Blue)
PG-408-1:	Die Inspection Gauge for #12 - #10 AWG (Yellow)
BAT18VLI:	18 Volt Lithium Battery Hi-Capacity 3.0 Ah
PATCHGR-LI:	120 V-AC Charger
PATCHGR-LIDC:	12/24 V-AC Charger



Close up  
PATMD1022-LI  
Die Set

US: 1-800-346-4175 / International: 1-603-647-5299 / Canada: 1-800-387-6487 / [www.burndy.com](http://www.burndy.com)

# Y750HSXT

## 12-Ton, C-Head, HYPRESS™ Hydraulic Self-Contained, Hand Operated Tool

- 355° head rotation
- 1.65" jaw opening
- Rapid advance pump
- Uses standard BURNDY U dies (sold separately)

### For Use On:

#### Tension Sleeves

Copper	#8 sol. - 500 kcmil
Aluminum	#8 sol. - 587.2 kcmil
ACSR	#4 - 556.5 kcmil

#### Taps

Copper	#14 sol. - 500 kcmil
Aluminum	#8 - 500 kcmil

#### Aerial Cable

Copper	#6 - 500 kcmil
--------	----------------

#### Terminals & Splices

Copper	#8 - 750 kcmil
Aluminum	#8 - 750 kcmil
ACSR	#4 - 556 kcmil

#### HYGROUND® (Compression Grounding)

Copper	#8 - 500 kcmil
Ground Rods	1/2" - 1" diameter

### Variations:

Y750CHSXT Rubber covered head version



### Specifications:

Output Force:	12 Tons
Tool Weight:	14.5 lbs
Size:	24.00" x 8.75" x 2.88"
Die Style:	U style
Jaw Opening:	1.65"
Warranty:	5 year limited warranty

### Accessories:

Y750HSCASE:	Plastic carrying case for Y750HSXT/Y750CHSXT
FORCEGAUGE12-15:	Force test gauge for accurate reading of output force
PT29291:	Steel die case for U dies

# Tooling

## Crimpers — Self-Contained Hydraulic



# Y35

### 12-Ton, C-Head, HYPRESS™

Hydraulic Self-Contained, Hand Operated Tool

- 180° head rotation
- Uses BURNDY U style dies (sold separately)
- Body and handles rubber covered for impact protection
- Trigger controlled ram release

#### For Use On:

Copper #8 str. - 500 kcmil code cable

##### Grounding Terminals:

YGH, YGHA, YGF

##### Grounding Splices:

YGS, YGHS

Copper #8 str. - 500 kcmil and up to 3/4" ground rod

##### Grounding Taps:

YGHC-C, YGHP-C, YGHR-C

Copper #8 str. - 750 kcmil code cable, N30 - N500 Navy cable, flexible, and extra flex

##### Terminals (Bare):

YA, YA-2N, YA-L, YA-LB, YA-2LN

##### Terminals (Insulated):

YAEV-L, YAEV-H, YAEV-RS, YAEV-RH

##### Splices to 400 kcmil only:

YS, YS-T, YS-L, YS-LB, YSV-L, YSM

Aluminum #8 str. - 750 kcmil code cable

##### Terminals:

YA-A, AYP, AYPO

##### Splices to 350 kcmil only:

YSA, YRB, YS-AT

ACSR:

See Overhead Transmission and Distribution sections in the BURNDY Master Catalog



#### Specifications:

Output Force:	12 Tons
Tool Weight:	13.0 lbs
Size:	23.25" x 8.75" x 4.75"
Die Style:	U style
Warranty:	5 year limited warranty

#### Variations:

Y35-2                      Y35 with rubber covered head, body, and handles



**Y39****12-Ton, Latch Head, HYPRESS™**  
Hydraulic Self-Contained, Hand Operated Tool

- 180° head rotation
- Body and handles rubber covered for impact protection
- Trigger controlled ram release
- Uses standard BURNDY U dies (sold separately)

**For Use On:****Copper #6 AWG - 750 kcmil str. Code Cable**  
**N30 - N650 Navy Cable, Flexible, and Extra Flexible**

Terminals (Bare):

YA, YA-L, YA-LB, YGH, YGHA

Splices and Tees (Bare):

YS, YS-L, YS-LB, YS-T, YSP-T, YST

**Copper AN or AIR #6 AWG - 4/0 str. Code Cable**  
**AN6 - AN4/0 Aircraft Cable, Flexible, and Extra Flexible**

Terminals (Bare):

YAV-L, YAV-RS

Splices (Bare):

YSV-L

**Copper #8 AWG - 2/0 str. Code Cable**  
**AN8 - AN2/0 Aircraft Cable, Flexible, and Extra Flexible**

Terminals (Insulated):

YAEV-L, YAEV-RS, YAEV-RH

**Copper #12 AWG sol. - 250 kcmil**

Taps:

YC-C, YGHC-C, YGHP-C, YGHR-C

**Aluminum #8 AWG - 750 kcmil Code Cable**

Terminals:

YA-A

Splices:

YS-A, YS-AT, YRB

**Aluminum #6 str. - 500 kcmil**

Taps:

YFD, YFN, YFO

**Specifications:**

<b>Output Force:</b>	12 Tons
<b>Tool Weight:</b>	12.0 lbs
<b>Size:</b>	23.00" x 8.75" x 4.00"
<b>Die Style:</b>	U style
<b>Warranty:</b>	5 year limited warranty

**Accessories:**

PT2972: Metal Carrying Case

# Tooling

## Crimpers — Self-Contained Hydraulic



### Y644HSXT

#### 11-Ton, Dieless Latch Head

Hydraulic Self-Contained, Hand Operated Tool

- 355° head rotation
- Dieless System
- Range taking capabilities
- Only “1” crimp necessary for most standard and long barrel terminals and splices
- Easy inspection; positive identification proved with BURNDY® ‘Bug’ (⊖) embossment after crimp completion

#### For Use On:

Copper #6 - 1000 kcmil

##### Terminals:

YA-L, YA-2-LN, YA, YA-FXB, YA-2N, YA-L-2TC, YA-L-FX,  
YAB-4N, YA-L-TC, YA-2L, YA-4N, YEV-P-FX, YE-P,  
YE-P-FX

##### Splices:

YS-L, YS, YS-T

Aluminum #6 str. - 750 kcmil

##### Terminals:

YA-A, YA-A-TN

##### Splices:

YS-A

##### HYPLUG™:

AYP, AYPO

*See Expanded Range details in Reference Section*



#### Specifications:

Output Force:	11 Tons
Tool Weight:	15.0 lbs
Size:	23.25" x 7.13" x 3.00"
Die Style:	Dieless
Warranty:	5 year limited warranty

#### Accessories:

Y644HSCASE: Plastic carrying case (included with tool)

# Y81KFT

## 6-Ton, 4-POINT® Dieless Latch Head Hydraulic Self-Contained, Hand Operated Tool

- Dieless System
- Range taking capabilities
- Flip top latch head design
- 360° head rotation

### For Use On:

Copper #8 -1000 kcmil

**Terminals:** YA, YA-L

**Splices:** YS-L, YS, YS-T, Y-R

Copper Flex #8 - 777.7 kcmil Flex (750 Nominal)

**Terminals:** YA-FX, YAV, YA-L-FX

**Splices:** YS, YSV-FXB

Aluminum #8 - 750 kcmil

**Terminals:** YA-A, YA-A-TN

**Splices:** YS-A

**HYPLUG™:** AYP, AYPO

*See Expanded Range details in Reference Section*



### Specifications:

<b>Output Force:</b>	6 Tons
<b>Tool Weight:</b>	12.0 lbs
<b>Size:</b>	25.62" x 7.75" x 2.50"
<b>Die Style:</b>	Dieless
<b>Warranty:</b>	5 year limited warranty

### Accessories:

<b>PT10050733:</b>	Plastic Carrying Case (included with the tool)
--------------------	--

# Tooling

## Crimpers — Self-Contained Hydraulic



### Y4PC834

#### 6-Ton, 4-POINT® Dieless C-Head Hydraulic Self-Contained, Hand Operated Tool

- 360° head rotation
- Dieless System
- Range taking capabilities
- Handle trigger release

#### For Use On:

Copper #8 -1000 kcmil

**Terminals:** YA, YA-L

**Splices:** YS-L, YS, YS-T, Y-R

Copper Flex #8 - 777.7 kcmil Flex (750 Nominal)

**Terminals:** YA-FX, YAV, YA-L-FX

Copper Flex #8 - 535 kcmil Flex (500 Nominal)

**Splices:** YS, YS-LB, YSV-FXB

Aluminum #8 - 750 kcmil

**Terminals:** YA-A, YA-A-TN

**Splices:** YS-A

**HYPLUG™:** AYP, AYPO

*See Expanded Range details in Reference Section*



#### Specifications:

<b>Output Force:</b>	6 Tons
<b>Tool Weight:</b>	11.9 lbs
<b>Size:</b>	25.62" x 7.75" x 2.50"
<b>Die Style:</b>	Dieless
<b>Warranty:</b>	5 year limited warranty

#### Accessories:

<b>PT10050733:</b>	Plastic Carrying Case (included with the tool)
--------------------	--

# Y500CT-HS

## 6-Ton, Latch Head, L'IL CRIMP™ Hydraulic Self-Contained, Hand Operated Tool

- Permanent functional D3 groove (no die needed)
- Used with W, X, and W-VT style dies
- 180° head rotation
- Enhanced clearance for tap connectors

### For Use On:

Copper, Aluminum, ACSR, Steel, Copperweld, Alumoweld, 6201, 5005, Compressed, Compact, Stranded and Solid conductors

### Installs Splices, Taps or Terminations:

- #8 - 600 kcmil Copper Str.
- #8 - 350 kcmil Flex
- #8 - 350 kcmil Aluminum



### Specifications:

<b>Output Force:</b>	6 Tons
<b>Tool Weight:</b>	7.8 lbs
<b>Size:</b>	17.63" x 6.00" x 2.68"
<b>Die Style:</b>	W, W-VT and X styles
<b>Warranty:</b>	5 year limited warranty



**WDC4500** range taking die for #4 - 500 Cu Str. and #2 - 4/0 Cu Flex (sold separately)



**WDA8300** range taking die for #8 - 300 Al, #6 - 400 Cu Str. and #2 - 4/0 Cu Flex (sold separately)

### Accessories:

- WDC4500:** Range taking die for #4 - 500 Cu Str. and #2 - 4/0 Cu Flex
- WDA8300:** Range taking die for #8 - 300 Al, #6 - 400 Cu Str. and #2 - 4/0 Cu Flex
- PT212851:** Metal Carrying Case

When used with UL Listed/CSA Certified YA, YS, YA-A, and YS-A series terminals and splices, connections are UL/CSA.

Range taking dies also for use on the YAV and YSV series.

# Tooling

## Crimpers — Remote Hydraulic



### Y60LW

#### 60-Ton, Lightweight Remote Latch Head Single Acting Lightweight Hydraulic Tool

- Remote power operated
- Used with BURNDY L and wide L style dies
- Base stand and metal carry case (for head only) included
- Side lift handle

#### For Use On:

Copper 300 - 2000 kcmil Str. Code Cable

**Terminals:** YA, YA-2N, YA-4N, YA-L, YA-2LN, YA-LB

**Splices:** YS, YST, YS-L, YS-T, YSP-T

Aluminum 250 - 2000 kcmil Str. Code Cable

**Terminals:** YA-A

**Splices:** YS-A, YS-AT

#### Transmission & Distribution Connectors:

##### Tension Sleeves:

Copper: 1/0 str. - 1000 kcmil

Aluminum: 1/0 str. - 2300 kcmil

ACSR: 1/0 str. - 2156 (84/19 str.) kcmil

Aerial:

Copper: 4/0 str. - 2500 kcmil

Aluminum: 3/0 str. - 2500 kcmil

Types: YTS, YTN, YNS, YNA, YNT, YNTA, YNU, YDS, YDN,  
YCS, YCA, YCU



**Y60LWCASE;** fits Y60LW  
head only (included)



#### Specifications:

<b>Output Force:</b>	60 Tons
<b>Tool Weight:</b>	43.0 lbs
<b>Size:</b>	13.00" x 8.12" x 8.12"
<b>Die Style:</b>	L style (standard or wide style)
<b>Operating Pressure:</b>	10,000 PSI
<b>Warranty:</b>	5 year limited warranty

#### Accessories:

- Y60LWSTAND:** Metal stand for Y60LW (included with tool)  
**Y60LWCASE:** Steel carry case for Y60LW head (included with tool)

**See Hydraulic Pumps and Hydraulic Hoses; Pump Accessories for other necessary equipment.**



**Y60LW** pictured on  
Y60LWSTAND (included)

US: 1-800-346-4175 / International: 1-603-647-5299 / Canada: 1-800-387-6487 / [www.burndy.com](http://www.burndy.com)

# Y60BHU

## 60-Ton, Remote, Latch Head Single Hydraulic Tool Design

- Remote power operated
- Heavy duty carry handle
- Long life expectancy
- 10,000 PSI operating pressure

### For Use On:

Copper 300 -2000 kcmil Str. Code Cable

**Terminals:** YA, YA-2N, YA-4N, YA-L, YA-2LN, YA-LB

**Splices:** YS, YST, YS-L, YS-T, YSP-T

Aluminum 250 - 2000 kcmil Str. Code Cable

**Terminals:** YA-A

**Splices:** YS-A, YS-AT

### Transmission & Distribution Connectors:

#### Tension Sleeves:

Copper: 1/0 str. - 1000 kcmil

Aluminum: 1/0 str. - 2300 kcmil

ACSR: 1/0 str. - 2156 (84/19 str.) kcmil

Aerial:

Copper: 4/0 str. - 2500 kcmil

Aluminum: 3/0 str. - 2500 kcmil

Types: YTS, YTN, YNS, YNA, YNT, YNTA, YNU, YDS, YDN,  
YCS, YCA, YCU

### Variations:

**Y60BHUD** Double action

*See Hydraulic Pumps and Hydraulic Hoses; Pump Accessories  
for other necessary equipment.*



### Specifications:

<b>Output Force:</b>	60 Tons
<b>Tool Weight:</b>	70.0 lbs
<b>Size:</b>	11.38" x 16.12" x 6.75"
<b>Die Style:</b>	L styles (standard or wide style)
<b>Operating Pressure:</b>	10,000 PSI
<b>Cycles:</b>	50,000
<b>Warranty:</b>	5 year limited warranty



*Wide L-dies (sold separately) can be used to save time and labor! Indicator marks on die set for ease of aligning connector properly. L725W shown.*

# Tooling

## Crimpers — Remote Hydraulic



### Y46LWSBH

#### 15-Ton, Remote Scoop Style C-Head Remote Operated Hydraulic Tool

- 2" jaw opening
- Used with P dies; U dies with PUADP-1 adapter (sold separately)
- Lifting eye
- Positive push button die locks
- Lightweight engineered open head design

#### For Use On:

##### Copper - #8 AWG Str. - 1500 kcmil

Code Cable, Navy Cable, Flexible, Extra Flexible  
1/2" - 1" Ground Rods

##### Terminals, grounding:

to 500 kcmil; YGA, YGHA, YGF

##### Terminals, uninsulated:

#8 - 1500 kcmil; YA, YA-2N, YA-L, YA-LB, YA-TC,  
YA-2LN, YAB-4N, YAV-L, YAV-RS, YA-TC-FX

##### Terminals, insulated:

#8 - 2/0; YAEV-L, YAEV-H, YAEV-RS, YAEV-RH

##### Splices:

#8 - 1500 kcmil; YS, YS-T, YS-L, YS-LB, YST,  
YSP-T, YGS, YGHS

##### Taps:

#14 - 1000 kcmil; YH, YCHC  
to 4/0 AWG; YC-C

##### Taps, grounding:

to 500 kcmil; YGHC-C, YGHP-C, YGHR-C

##### Aluminum - #8 AWG - 1250 kcmil

Code Cables

**Terminals:** YA-A, AYP, AYPO

**Splices:** YS-A, YS-AT, YRB

**Taps:** YFD, YFN, YFO, YFR

**ACSR** - see Overhead Transmission & Distribution  
Sections of the BURNDY® Master Catalog

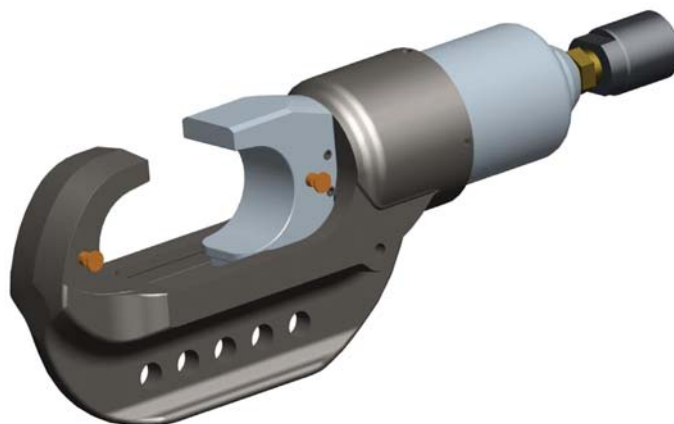

#### Specifications:

<b>Output Force:</b>	15 Tons
<b>Tool Weight:</b>	14.5 lbs
<b>Size:</b>	14.68" x 5.12" x 2.88"
<b>Die Style:</b>	P style and U style with PUADP-1 adapter
<b>Operating Pressure:</b>	10,000 PSI
<b>Cycles:</b>	10,000
<b>Warranty:</b>	5 year limited warranty

#### Accessories:

<b>PUADP-1:</b>	U die adapter
<b>P15K:</b>	Cutter Die, max. diameter 1.2"

*See Hydraulic Pumps and Hydraulic Hoses; Pump Accessories  
for other necessary equipment.*

#### Variations:

<b>Y46CLWSBH</b>	Permanently molded head of 3/16" rubber included separate molded rubber boot for lower body and hydraulic coupler
<b>Y46CLWSBHF</b>	Y46CLWSBH (covered) tool with female coupler
<b>Y46LWSBHF</b>	Y46LWSBH tool with Female coupler (not rubber covered)



# Y46LWBH

## 15-Ton, Remote Latch Head

Remote Operated Hydraulic Tool

- 2" ram travel
- Used with P dies; U dies with PUADP-1 adapter (sold separately)
- Positive push button die locks
- Lightweight latch head design

### For Use On:

#### Copper - #8 AWG Str. - 1500 kcmil

Code Cable, Navy Cable, Flexible, Extra Flexible  
1/2" - 1" Ground Rods

#### Terminals, grounding:

to 500 kcmil; YGA, YGHA, YGF

#### Terminals, uninsulated:

#8 - 1500 kcmil; YA, YA-2N, YA-L, YA-LB, YA-TC,  
YA-2LN, YAB-4N, YAV-L, YAV-RS, YA-TC-FX

#### Terminals, insulated:

#8 - 2/0; YAEV-L, YAEV-H, YAEV-RS, YAEV-RH

#### Splices:

#8 - 1500 kcmil; YS, YS-T, YS-L, YS-LB, YST,  
YSP-T, YGS, YGHS

#### Taps:

#14 - 1000 kcmil; YH, YCHC  
to 4/0 AWG; YC-C

#### Taps, grounding:

to 500 kcmil; YGHC-C, YGHP-C, YGHR-C

#### Aluminum - #8 AWG - 1250 kcmil

Code Cables

**Terminals:** YA-A, AYP, AYPO

**Splices:** YS-A, YS-AT, YRB

**Taps:** YFD, YFN, YFO, YFR

**ACSR** - see Overhead Transmission & Distribution  
Sections of the BURNDY<sup>®</sup> Master Catalog



### Specifications:

<b>Output Force:</b>	15 Tons
<b>Tool Weight:</b>	12.4 lbs
<b>Size:</b>	14.88" x 5.12" x 3.12"
<b>Die Style:</b>	P style and U style with PUADP-1 adapter
<b>Operating Pressure:</b>	10,000 PSI
<b>Cycles:</b>	10,000
<b>Warranty:</b>	5 year limited warranty

### Accessories:

<b>PUADP-1:</b>	U die adapter
<b>P15K:</b>	Cutter Die max. diameter 1.2"

*See Hydraulic Pumps and Hydraulic Hoses; Pump Accessories for other necessary equipment.*

### Variations:

<b>Y46LWBHF</b>	Y46LWBH tool with Female coupler (not rubber covered)
-----------------	---

# Tooling

## Crimpers — Remote Hydraulic



# Y45

### 15-Ton, Remote C-Head

Remote Operated Hydraulic Tool

- Lifting eye
- Fully protected ram and die buttons
- Used with S dies; U dies with PT6515 adapter (sold separately)

#### For Use On:

##### Tension Sleeves:

- Copper #8 sol. - 500 kcmil
- Aluminum #6 sol. - 954 kcmil
- ACSR #4 - 795 (26/7) kcmil

##### Taps:

- Aluminum #14 - 954 (18/1) kcmil
- ACSR #6 - 795 (54/7) kcmil

##### Aerial Cable Connectors:

- Copper #6 str. - 1500 kcmil
- Aluminum #4 str. - 1000 kcmil

##### HYGROUND® Compression Grounding:

- Copper #6 - 500 kcmil
- 1/2" - 1" ground rods

##### Code Cable Terminals/Splices:

- Copper #8 - 1500 kcmil
- Aluminum #8 - 1000 kcmil

##### Code Cable Taps:

- Copper #14 - 1000 kcmil
- Aluminum #14 - 900 kcmil



#### Specifications:

Output Force:	15 Tons
Tool Weight:	15.75 lbs
Size:	14.25" x 7.25" x 2.62"
Die Style:	S style and U style with PT6515 adapter
Operating Pressure:	10,000 PSI
Cycles:	10,000
Warranty:	5 year limited warranty

#### Accessories:

PT6515:	Adapter for use with U die sets
PT6545:	Die carrying case for S and/or P die type dies. Holds eight (8) die sets. Dies sold separately.

*See Hydraulic Pumps and Hydraulic Hoses; Pump Accessories for other necessary equipment.*

# Y750BHXT

## 12-Ton, Remote C-Head Remote Operated Hydraulic Tool

- 1.65" jaw opening
- 355° head rotation
- Used with U style dies
- Exposed positive die lock buttons

### For Use On:

#### Tension Sleeves

Copper	#8 sol. - 500 kcmil
Aluminum	#8 sol. - 587.2 kcmil
ACSR	#4 - 556.5 kcmil

#### Taps

Copper	#14 sol. - 500 kcmil
Aluminum	#8 - 500 kcmil

#### Aerial Cable

Copper	#6 - 500 kcmil
--------	----------------

#### Terminals & Splices

Copper	#8 - 750 kcmil
Aluminum	#8 - 750 kcmil
ACSR	#4 - 556 kcmil

#### HYGROUND® (Compression Grounding)

Copper	#8 - 500 kcmil
Ground Rods	1/2" - 1" diameter

### Variations:

<b>Y750CBHXT</b>	Y750BHXT with molded rubber covering on head, body and hose fittings
------------------	--



### Specifications:

<b>Output Force:</b>	12 Tons
<b>Tool Weight:</b>	10.3 lbs
<b>Size:</b>	12.88" x 5.25" x 3.12"
<b>Die Style:</b>	U style
<b>Jaw Opening:</b>	1.65"
<b>Operating Pressure:</b>	10,000 PSI
<b>Warranty:</b>	5 year limited warranty

### Accessories:

<b>PT29402-1:</b>	Adjustable head grip for joining head to universal hot sticks
<b>PT29291:</b>	Steel die case for storage and protection of U dies
<b>PT10054094:</b>	Canvas carry bag

*See Hydraulic Pumps and Hydraulic Hoses; Pump Accessories for other necessary equipment.*

# Tooling

## Crimpers — Remote Hydraulic



### Y35BH

#### 12-Ton, Remote C-Head

Remote Operated Hydraulic Tool

- Lifting eye
- .95" jaw opening
- Uses U style dies
- Positive die lock buttons

#### For Use On:

Copper #8 str. - 500 kcmil code cable

##### Grounding Terminals:

YGH, YGHA, YGF

##### Grounding Splices:

YGS, YGHS

Copper #8 str. - 500 kcmil and up to 3/4" ground rod

##### Grounding Taps:

YGHC-C, YGHP-C, YGHR-C

Copper #8 str. - 750 kcmil code cable, N30 - N500 Navy cable, flexible, and extra flex

##### Terminals (Bare):

YA, YA-2N, YA-L, YA-LB, YA-2LN

##### Terminals (Insulated):

YAEV-L, YAEV-H, YAEV-RS, YAEV-RH

##### Splices to 400 kcmil only:

YS, YS-T, YS-L, YS-LB, YSV-L, YSM

Aluminum #8 str. - 750 kcmil code cable

##### Terminals:

YA-A, AYP, AYPO

##### Splices to 350 kcmil only:

YSA, YRB, YS-AT

ACSR:

See Overhead Transmission and Distribution sections in the BURNDY Master Catalog



#### Specifications:

Output Force:	12 Tons
Tool Weight:	8.0 lbs
Size:	9.25" x 4.75" x 2.62"
Die Style:	U style
Jaw Opening:	.95"
Operating Pressure:	10,000 PSI
Cycles:	10,000
Warranty:	5 year limited warranty

#### Variations:

Y35H	Y35BH head, PT29402-1 universal hot stick adapter, and steel carrying case
Y35B	Y35BH head, PT91 steel reinforced hydraulic hose, and an FP10 foot pump in a steel carrying case. <b>Note:</b> NOT for use on energized conductors
Y35BH-4	Permanent molded rubber head, 3/16" rubber for tool impact protection

*See Hydraulic Pumps and Hydraulic Hoses; Pump Accessories for other necessary equipment.*

**Y39BH****12-Ton, Remote Latch Head**

Remote Operated Hydraulic Tool

- Used with U style dies
- Positive push button die locks

**For Use On:****Copper #6 AWG - 750 kcmil str. Code Cable**  
**N30 - N650 Navy Cable, Flexible, and Extra Flexible**

Terminals (Bare):

YA, YA-L, YA-LB, YGH, YGHA

Splices and Tees (Bare):

YS, YS-L, YS-LB, YS-T, YSP-T, YST

**Copper AN or AIR #6 AWG - 4/0 str. Code Cable**  
**AN6 - AN4/0 Aircraft Cable, Flexible, and Extra Flexible**

Terminals (Bare):

YAV-L, YAV-RS

Splices (Bare):

YSV-L

**Copper #8 AWG - 2/0 str. Code Cable**  
**AN8 - AN2/0 Aircraft Cable, Flexible, and Extra Flexible**

Terminals (Insulated):

YAEV-L, YAEV-RS, YAEV-RH

**Copper #12 AWG sol. - 250 kcmil**

Taps:

YC-C, YGHC-C, YGHP-C, YGHR-C, YH, YCHC

**Aluminum #8 AWG - 750 kcmil Code Cable**

Terminals:

YA-A

Splices:

YS-A, YS-AT, YRB

**Aluminum #6 str. - 500 kcmil**

Taps:

YFD, YFN, YFO

**Specifications:**

Output Force:	12 Tons
Tool Weight:	6.5 lbs
Size:	9.12" x 3.12" x 3.12"
Die Style:	U style
Operating Pressure:	10,000 PSI
Warranty:	5 year limited warranty

**Accessories:**

*See Hydraulic Pumps and Hydraulic Hoses; Pump Accessories for other necessary equipment.*

# Tooling

## Crimpers — Remote Hydraulic



# Y644MBH

## 11-Ton, Dieless Remote Head

Remote Operated Hydraulic Tool

- Dieless System
- Latch head design
- Range taking capabilities
- Infinitely rotatable head

### For Use On:

Copper #6 - 1000 kcmil

#### Terminals:

YA-L, YA-2-LN, YA, YA-2N, YA-L-2TC, YAB-4N, YA-L-TC,  
YA-2L, YA-4N

#### Splices:

YS-L, YS, YS-T

Aluminum #6 str. - 1000 kcmil

#### Terminals:

YA-A, YA-A-TN

#### Splices:

YS-A

#### HYPLUG™:

AYP, AYPO

*See Expanded Range details in Reference Section*



### Specifications:

Output Force:	11 Tons
Tool Weight:	9.5 lbs
Size:	12.00" x 4.00" x 3.12"
Die Style:	Dieless
Operating Pressure:	10,000 PSI
Warranty:	5 year limited warranty

### Accessories:

*See Hydraulic Pumps and Hydraulic Hoses; Pump Accessories for other necessary equipment.*

# Y81KFTMBH

## 6-Ton, 4-POINT® Dieless Remote Head Remote Operated Hydraulic Tool

- Dieless installation system
- Range taking capabilities
- Flip top design
- Incorporates Parker-type quick connect 3/8" male coupler
- 360° head rotation

### For Use On:

Copper #8 -1000 kcmil

**Terminals:** YA, YA-L

**Splices:** YS, YS-L, YS-T, Y-R

Copper Flex #8 - 777.7 kcmil Flex (750 Nominal)

**Terminals:** YA-FX, YAV, YA-L-FX

**Splices:** YS, YSV-FXB

Aluminum #8 - 750 kcmil

**Terminals:** YA-A, YA-A-TN

**Splices:** YS-A

**HYPLUG™:** AYP, AYPO

*See Expanded Range details in Reference Section*



### Specifications:

<b>Output Force:</b>	6 Tons
<b>Tool Weight:</b>	8.5 lbs
<b>Size:</b>	13.88" x 5.38" x 2.00"
<b>Die Style:</b>	Dieless
<b>Operating Pressure:</b>	10,000 PSI
<b>Warranty:</b>	5 year limited warranty

### Accessories:

PT10054094: Canvas carry bag

*See Hydraulic Pumps and Hydraulic Hoses; Pump Accessories  
for other necessary equipment.*

# Y4PC834MBH

## 6-Ton, 4-POINT<sup>®</sup>, Dieless Remote Head Remote Operated Hydraulic Tool

- Dieless System
- Range taking capabilities
- C-shaped head design
- 360° head rotation

### For Use On:

Copper #8 -1000 kcmil

**Terminals:** YA, YA-L

Copper #8 -500 kcmil

**Splices:** YS, YS-L, YS-T, Y-R

Copper Flex #8 - 777.7 kcmil Flex (750 Nominal)

**Terminals:** YA-FX, YAV, YA-L-FX

Copper Flex #8 -535 (500 Nominal)

**Splices:** YS, YS-LB, YSV-FXB

Aluminum #8 - 750 kcmil

**Terminals:** YA-A, YA-A-TN

Aluminum #8 - 350 kcmil

**Splices:** YS-A

**HYPLUG™:** AYP, AYPO

*See Expanded Range details in Reference Section*



### Specifications:

<b>Output Force:</b>	6 Tons
<b>Tool Weight:</b>	8.4 lbs
<b>Size:</b>	5.50" x 4.00" x 2.00"
<b>Die Style:</b>	Dieless
<b>Operating Pressure:</b>	10,000 PSI
<b>Warranty:</b>	5 year limited warranty

### Accessories:

PT10054094: Canvas carry bag

*See Hydraulic Pumps and Hydraulic Hoses; Pump Accessories for other necessary equipment.*



# Y34BH

## 9-Ton, Remote C-Head Remote Operated Hydraulic Tool

- Molded rubber covering on head, body, and hose fittings
- Fast ram retraction
- Compact C-shaped forged head

### For Use On:

Copper #4 - 500 kcmil code cable  
 Welding Cable: 350 kcmil  
 N40 to N500 Navy Cable  
 Flexible and Extra Flexible  
 #4 - 4/0 Aircraft Cable

**HYLUG™ Terminals (Bare)**  
**HYLINK™ Splices (Bare)**

**HYCRAB™ BURNDY® Network Connector System**  
 Copper: #4 - 500 kcmil str.  
 Aluminum: #6 - 300 kcmil

### Installation Die Charts for Y34BH

Copper Conductor		
Installation Die		Max. Conductor
Nest	Indenter	
B4CD	Y34PR	#4 Str.
B2CD	Y34PR	#2 Str.
B1CD	Y34PR	#1 Str.
B25D	Y34PR	1/0 Str.
B26D	Y34PR	2/0 Str.
B27D	Y34PR	3/0 Str.
B28D	Y34PR	4/0 Str.
B29D	Y34PR	250 kcmil
B30D	Y34PR	300 kcmil
B31D	Y34PR	350 kcmil
No Die Req'd	Y34PR	500 kcmil



### Specifications:

<b>Output Force:</b>	9 Tons
<b>Tool Weight:</b>	8.0 lbs
<b>Size:</b>	16.75" x 3.00" x 3.00"
<b>Die Style:</b>	B style nest & Y34 series indenter dies
<b>Jaw Opening:</b>	1.5"
<b>Operating Pressure:</b>	10,000 PSI
<b>Warranty:</b>	5 year limited warranty

### Variations:

**Y34BH-1** Y34BH with 10' non-conductive hose attached at factory

*See Hydraulic Pumps and Hydraulic Hoses; Pump Accessories for other necessary equipment.*

Aluminum Conductor		
Installation Die		Max. Conductor
Nest	Indenter	
B4CD	Y34PA	#6 Str.
B1CD	Y34PA	#4 Str.
B25D	Y34PA	#2 Str.
B26D	Y34PR-5	#1 Str.
B27D	Y34PR-5	1/0 Str.
B29D	Y34PR-5	2/0 Str.
B30D	Y34PR-5	3/0 Str.
B31D	Y34PR-5	4/0 Str.
B32D	Y34PR-5	250 kcmil
No Die Req'd	Y34PR-11	300 kcmil

# Tooling

## Crimpers — Remote Hydraulic



# Y29BH

## 4.5-Ton, 6,000 PSI Remote Head

Remote Operated Hydraulic Tool

- D series nest dies and Y29 series indenter dies
- Lightweight, portable design
- C-shaped head; 1.2" jaw opening
- Easy placement/removal on continuous conductors lengths

### For Use On:

Copper #8 - 2/0 AWG Code/Flex

#### Nylon Insulated Lugs:

(Connectors meet MIL-T-7928 requirements)  
YAEV-L, YAEV-H, YAEV-RS, YAEV-RH

#### Non-Insulated Lugs:

(Connectors meet MIL-T-7928 requirements)  
YAV-L, YAV-R, YAV-RS

Copper #8 - 4/0 AWG

#### Non-Insulated Splices:

(Type YSV-L connectors UL Listed/CSA Certified)  
YSM, YSV-L

### Installation Die Chart for Y29BH

(Connectors meet MIL-T-7928 requirements)

Non-Insulated Connectors		Maximum Conductor	Insulated Connectors	
Nest	Indenter	Size	Nest	Indenter
DV8L-1	Y29PL	#8 AWG	DEV8L	Y29PLE-1
DV6L	Y29PL	#6 AWG	DEV6L	Y29PLE-1
DV4L	Y29PL	#4 AWG	DEV4L	Y29PLE-1
DV2L	Y29PL	#2 AWG	DEV2L	Y29PLE
DV1L	Y29PL	#1 AWG	DEV1L	Y29PLE
DV25L	Y29PL	1/0 AWG	DEV25L	Y29PLE
DV26L	Y29PL	2/0 AWG	DEV26L	Y29PLE



### Specifications:

Output Force:	4.5 Tons
Tool Weight:	5.0 lbs
Size:	10.75" x 3.00" x 1.25"
Die Style:	D style nest & Y29 series indenter dies
Jaw Opening:	1.15"
Operating Pressure:	6,000 PSI
Warranty:	5 year limited warranty

### Accessories:

See Hydraulic Pumps and Hydraulic Hoses; Pump Accessories for other necessary equipment.



PT30250 metal carrying case included with tool

US: 1-800-346-4175 / International: 1-603-647-5299 / Canada: 1-800-387-6487 / www.burndy.com

## Plier Hand Tools

### Y10D for Nylon & Bare

Hand-held plier tool for #22 - #10 AWG

- One tool for both nylon insulated and bare connectors
- Precision machined wire cutter for aluminum and copper
- Heavy duty forged steel, rust resistant finish

### Y10-22 for Nylon, Vinyl & Bare

Hand-held plier tool for #22 - #10 AWG

- One step stripping #22 - #10 AWG
- Cuts common size mild steel, non-ferrous screws
- Crimps full range of Nylon, Vinyl and Bare terminals and splices

#### For Use On:

#### Y10D:

#### #22 - #10 AWG Nylon Insulated Terminals

Types: TN, TN-F, YAE-N, YAE-N-F, YAE-Z, YAEV, YAES, YAES-E

#### #22 - #10 AWG Nylon Insulated Splices

Types: SN, YSE-HN\*, SNM, YSES, YSE-H\*

#### #22 - #10 AWG Bare Uninsulated Terminals

Types: T, YAD, T-F, YAD-F, YAV, YAV-T-F, YAV-H\*, YAV-H-F\*, YAV-Z

#### #22 - #10 AWG Bare Uninsulated Splices

Types: YSV, YSV-H\*

#### Y10-22 all of above and also:

#### #22 - #10 AWG Vinyl Insulated Terminals

Types: TP, BA, TP-F, BA-EF, TP-Z, BA-EZ

#### #22 - #10 AWG Vinyl Insulated Splices

Types: SP, BS

\*Conductor crimp only



#### Specifications: (Y10D)

Size:	9.75" x 5.00" x 1.00"
Weight:	13.5 oz.
Warranty:	5 year limited warranty



#### Specifications: (Y10-22)

Size:	8.63" x 5.00" x .75"
Weight:	11 oz.
Warranty:	5 year limited warranty

# Tooling

## Crimpers — Mechanical & Ratchet



### YF22-10FL

#### Dieless, Front Load, Ratchet for Ferrules

Full cycle ratchet tool for insulated/bare ferrules

- Front load crimping position
- Dieless crimping without multiple grooves
- Full cycle ratchet mechanism
- Ratchet release lever

#### For Use On:

#22 - #10 AWG Insulated and Uninsulated (Bare) Ferrules

Types: YF, YF-UI Wire End Ferrules



#### Specifications:

Size:	7.75" x 2.38 x 1.00"
Die Style:	Dieless
Weight:	.8 lbs
Output Force:	1,600 lbs
Warranty:	5 year limited warranty

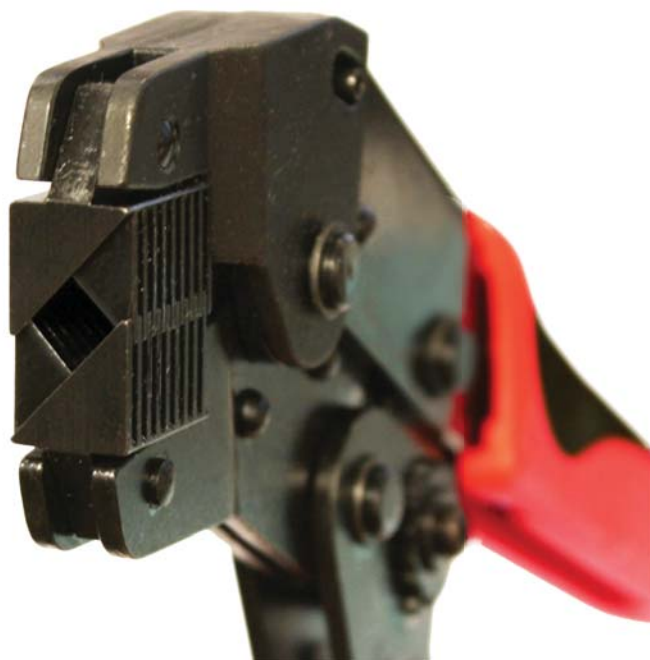

Close up of YF22-10FL front load ratchet tool



Crimp Profile

## YF-TOOL Series

### Ratchet Tools for Insulated/Bare Ferrules

Tools covering from #32 AWG to 250 kcmil

- Release mechanism
- Low handle force
- Ergonomic handle design
- Trapezoidal crimp profile unless noted

#### For Use On:

#32 - #6 AWG Insulated and Uninsulated (Bare) Ferrules  
Tool: **YF3206TOOL** (Square crimp profile)

#26 - #10 AWG Insulated and Uninsulated (Bare) Ferrules  
Tool: **YF2610TOOL**

#22 - #14 AWG Insulated and Uninsulated (Bare) Ferrules  
Tool: **YF2214TOOL**

#22 - #10 AWG Insulated and Uninsulated (Bare) Ferrules  
Tool: **YF2210TOOL**

#10 - #6 AWG Insulated and Uninsulated (Bare) Ferrules  
Tool: **YF1006TOOL**

#8 - #1 AWG Insulated and Uninsulated (Bare) Ferrules  
Tool: **YF0801TOOL**

#4 - #1 AWG Insulated and Uninsulated (Bare) Ferrules  
Tool: **YF0401TOOL**

#1/0 - #3/0 kcmil Insulated and Uninsulated (Bare) Ferrules  
Tool: **YF1/03/0TOOL**

#4/0 - #250 kcmil Insulated and Uninsulated (Bare) Ferrules  
Tool: **YF4/0250TOOL**



#### Specifications:

<b>Length:</b>	varies
<b>Weight:</b>	varies from 1.02 to 1.80 lbs
<b>Warranty:</b>	2 year limited warranty

## Y8MRB-1

### Full Cycle Ratchet Tool

Hand-held ratchet tool for #22 - 8 AWG

- Light weight
- Each indenter has unique identifying marks for inspectability
- Fully enclosed, protected ratchet mechanism does not allow the handles to be opened until full ratchet cycle is completed
- Inspection gauges (sold separately) available to check each groove

#### For Use On:

##### #22 - 8 AWG Uninsulated (Bare) Terminals:

Types: T, YAD, T-F, YAD-F, YAV, YAV-L, YAV-T-F, YAV-Z

##### #22 - 8 AWG Uninsulated (Bare) Splices:

Types: YSV, YSV-L



#### Specifications:

Weight:	1.2 lbs
Size:	10.56" x 3.50" x 1.12"
Die Style:	Permanent Dies
Warranty:	5 year limited warranty

#### Accessories:

PG395-1	Inspection gauge for #18 groove
PG396-1	Inspection gauge for #14 groove
PG397-1	Inspection gauge for #10 groove
PG398-1	Inspection gauge for #8 groove

## MR8 Series

### Fully Protected Ratchet Mechanism

Full cycle ratchet tools for critical applications

- Fully enclosed, protected ratchet mechanism does not allow the handles to be opened until full ratchet cycle is completed
- Designed for critical applications such as nuclear-class 1E terminations, heavy duty industrial, aircraft
- Lightweight aluminum
- Easy groove identification with color-coded dies

#### For Use On:

**MR8-1A:** #22 - #10 AN Copper Cable  
INSULUG™ terminals/splices  
YAE

**MR8-9Q:** #18 - #8 AN Copper Cable  
#22 - #10 AWG Sol. Cable  
#22 - #8 AWG Str. Cable  
YAV, YSV, T, T-F, YAD, YAD-F

**MR8-33S-1,  
MR8-33T-1:** #18 - #10 MIL-W-5086 Str.  
YSE, YSE-H

**MR8-G96:** #22 - #14  
TP, BA

**MR8-G98:** #22 - #10  
YAV, T, YAD



#### Specifications:

<b>Size:</b>	10.50" x 3.50" x 1.50"
<b>Weight:</b>	1.5 lbs
<b>Die Style:</b>	Permanent Dies
<b>Warranty:</b>	5 year limited warranty

# Y10MRSA1

## Ergonomic Full Cycle Ratchet

Hand-held tool using J-dies for #22 - #10 AWG

- Compact, narrow nose with scissor action
- Uses J-style die inserts (sold separately)
- High-strength steel frame, rubber covered comfort handles
- Ergonomic design requires less handle force

### For Use On:

with J1022NC1 die (sold separately):

**#22 - #10 AWG Nylon Insulated Terminals/Splices**

Types: YAE, YAE-N, YAE-N-F, YAE-Z

with J1022NC2 die (sold separately):

**#22 - #10 AWG Nylon Insulated Terminals/Splices**

Types: YAEV, YAEV-L, YAEV-H, YAEV-RH, YAEV-RS

with J1022NC3 die (sold separately):

**#22 - #10 AWG Nylon Insulated Terminals/Splices**

Types: TN, YAES, TN-F, YAES-F, SN, YSE-HN

with J1022NC4 die (sold separately):

**#22 - #10 AWG Vinyl Insulated Terminals/Splices**

Types: TP, BA, TP-F, BA-EF, TP-Z, BA-EZ, TP-LF, BA-EL, SP, BS

with J1022NC5 die (sold separately):

**#22 - #10 AWG Uninsulated (Bare) Terminals/Splices\***

Types: T, YAD, T-F, YAD-F, YAV, YAV-L, YAV-H, YAV-R, YAV-RS, YAV-T-F, YAV-H-F, YAV-Z, YSV, YSV-H, YSV-L

\* Wire barrel only

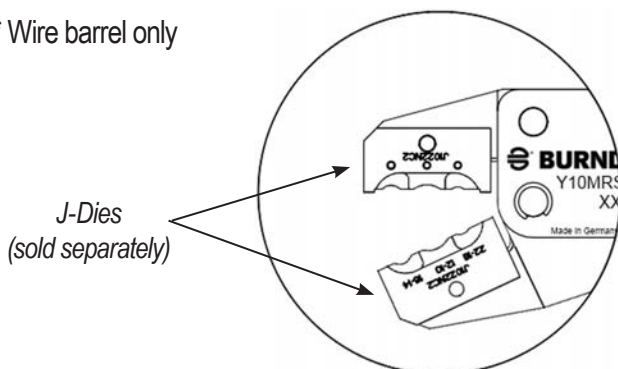

### Specifications:

<b>Size:</b>	10.75" x 3.12" x 1.88"
<b>Die Style:</b>	J style
<b>Weight:</b>	1.3 lbs
<b>Warranty:</b>	5 year limited warranty

### Accessories:

<b>J1022NC1:</b>	J die set see detail under For Use On section
<b>J1022NC2:</b>	J die set see detail under For Use On section
<b>J1022NC3:</b>	J die set see detail under For Use On section
<b>J1022NC4:</b>	J die set see detail under For Use On section
<b>J1022NC5:</b>	J die set see detail under For Use On section



### MRE10-22 Series

#### Ergonomic Full Cycle Ratchet

Hand-held tools for #22 - #10 AWG Nylon/Vinyl & Bare

- Ratchet mechanism does not allow handles to open until full cycle is complete
- Stop plate ensures proper location for consistent reliable connection
- Die Inspection Gauges available (sold separately)
- Easy groove identification with color coded dies
- Ratchet release lever in case of misalignment

#### For Use On:

##### MRE10-22B

**#22 - #10 AWG Uninsulated (Bare) Terminals/Splices**

Types: T, YAD, T-F, YAD-F, YAV, YAV-H, YAV-R, YAV-T-F, YAV-H-F, YAV-Z, YSV, YSV-H

##### MRE10-22NV

**#22 - #10 AWG Nylon & Vinyl Insulated Terminal/Splices**

Types: TP, BA, TP-F, BA-EF, TP-Z, BA-EZ, TP-LF, BA-EL, SP, BS, TN, YAES, TN-F, YAES-F, SNM\*, YSES\*, YAE-N, YAE-N-F, YAE-Z, YSE-HN, YSE-H, YAEV

\*Excludes #10 size



#### Specifications:

Weight:	1.3 lbs
Size:	10.50" x 3.00"
Width:	3"
Die Style:	Permanent Dies
Warranty:	5 year limited warranty

#### Accessories:

PG-403-2R	Die Inspection Gauge for #22 - #14 AWG for MRE10-22B
PG-403-1R	Die Inspection Gauge for #12 - #10 AWG for MRE10-22B
PG-406-1:	Die Inspection Gauge for #22 - #18 AWG (Red) for MRE10-22NV
PG-407-1:	Die Inspection Gauge for #16 - #14 AWG (Blue) for MRE10-22NV
PG-408-1:	Die Inspection Gauge for #12 - #10 AWG (Yellow) for MRE10-22NV



Close-up  
MRE10-22NV

## MR Series

### Full Cycle Ratchet

Hand-held tools for #22 - #10 AWG

- Ratchet mechanism does not allow handles to open until full cycle is complete
- Easy groove identification with color coded dies
- Compact, narrow nose
- Comfort grip handles
- Ratchet release lever in case of misalignment

#### For Use On:

##### MR15

**#22 - #10 AWG Vinyl Insulated Terminals/Splices**

Types: TP, BA, TP-F, BA-EF, TP-Z, BA-EZ, TP-LF, BA-EL, SP, BS

##### MR18

**#22 - #10 AWG Nylon Insulated Terminals/Splices**

Types: TN, TN-F, YAES, YAES-F, SN, SNM, YSE-HN, YSES

##### MR20

**#22 - #10 AWG Uninsulated (Bare) Terminals/Splices**

Types: T, YAD-F, T-F, YAV-H\*, YAV, YAV-H-F\*, YAD, YAV-T-F, YSV, YSV-H\*

\*Conductor crimps only



#### Specifications:

<b>Size:</b>	8.88" x 6.00" x 2.50" (closed)
<b>Weight:</b>	1.1 lbs
<b>Warranty:</b>	5 year limited warranty

#### Accessories:

<b>MR15DIESETD1:</b>	MR15 interchangeable die set
<b>MR18DIESETD1:</b>	MR18 interchangeable die set
<b>MR20DIESETD1:</b>	MR20 interchangeable die set

**MR4C****Full Cycle Ratchet**

Hand-held tool for #9 - #4 AWG Bare Terminals/Splices

- Reinforced heavy duty back with high strength aluminum body
- Fully protected ratchet mechanism does not allow handles to open until full cycle is completed
- Inspection gauges available to check each groove (sold separately)
- Spring loaded indenter jaw, keeps jaws closed

**For Use On:****#9 - #4 AWG Uninsulated (Bare) Terminals/Splices**

Types: YAV-L, YA-L, YSV, YSM, YS-L

**Specifications:**

<b>Length:</b>	11.75" x 3.62" x 1.00"
<b>Weight:</b>	2.3 lbs
<b>Die Style:</b>	Permanent Dies
<b>Warranty:</b>	5 year limited warranty

**Accessories:**

<b>PG121-1:</b>	Die Inspection Gauge for #9 - #8 AWG groove
<b>PG125-1:</b>	Die Inspection Gauge for #6 AWG groove
<b>PG133-1:</b>	Die Inspection Gauge for #4 AWG groove

# Tooling

## Crimpers — Mechanical & Ratchet



# Y1MRTC

## Rotating Die Full Cycle Ratchet

For #8 - #1 Copper HYDENT™ Terminals, Splices and #6 - #6 Thin-Wall C-Taps

- Die index embossment
- Rotating die with color coding to match connectors
- Ratchet mechanism with release in case of misalignment

### For Use On:

See charts for details

#8 - #1 AWG Uninsulated (Bare) Terminals and Splices

Types: YA, YAV, YS, YSV

Thin Wall C-Taps:

YC10L12, YC8L12, YC6L12, YC4L12



### Specifications:

<b>Size:</b>	9.88" x .75" x 2.75"
<b>Weight:</b>	1.7 lbs
<b>Die Style</b>	Rotating Die Wheel
<b>Warranty:</b>	5 year limited warranty

Copper Terminals & Splices				
Copper Wire Size	Connector Catalog Types	Die Index # (Color)	# Crimps per Barrel Length	
			Std	Long
#8 AWG Code & Flex	YA8C- YS8C- YAV8C- YSV8C-	49 (Red)	1	2
#6 AWG Code	YA6C- YS6C-	7 (Blue)	1	2
#6 AWG Code & Flex	YAV6C- YSV6C-			
#4 AWG Code	YA4C- YS4C-	8 (Grey)	2	4
#4 AWG Code & Flex	YAV4C- YSV4C-			
#3 AWG #2 Sol.	YA3C- YS3C-	9 (White)	2	4
#2 AWG Code	YA2C- YS2C-	10 (Brown)**	2	4
# 2 AWG Code & Flex	YAV2C- YSV2C-			
#1 AWG Code	YA1C- YS1C-	11 (Green)**	2	4

\*\*Die Index 10/Brown and 11/Green use the same die wheel crimp groove.

Copper C-Tap Connectors				
Catalog Number	Wire Size Cu Str. AWG		Die Index # (Color)	# of Crimps
	Run	Tap		
YC10L12	14	16-14	49 (Red)	1
	12	16-14		
	10	16		
YC8L12	10	10	7 (Blue)	1
	8	12		
YC6L12	8	10-8	8 (Grey)	1
	6	12-10		
YC4L12	6	8-6	10 (Brown)	2
	5, 4	12-8		

### Variations:

- Y1MRKIT** Y1MRTC tool, sturdy metal carrying case and select terminals/splices
- Y1MRTCKIT** Y1MRTC tool, sturdy metal carrying case, selected terminals and YC4L12 Thin-Wall C-Tap

US: 1-800-346-4175 / International: 1-603-647-5299 / Canada: 1-800-387-6487 / [www.burndy.com](http://www.burndy.com)

# Y122CMR

## Ergonomic Full Cycle

For #12 - #2 AWG Class B, Class I Flex, #2 Sol., 3 Str.

- Overmolded comfort grip handles
- Easy groove identification with color coded dies
- UL Listed/CSA Certified connections when used with recommended BURNDY terminals/splices
- Die index embossment

Cu Lug and Splice Connectors			
Copper Wire Size	Connector Catalog Types	Die Index # (Color)	# of Crimps
#12-10AWG Sol., Str., & Flex	YAZV10TC- YAZV102TC- YAZV102TC-	(Yellow)	2
# 8 AWG Code & Flex	YAZ8C-	49 (Red)	2
#6 AWG Code & Flex	YAZ6C- YAV6C-	7 (Blue)	2
#4 AWG Code & Flex	YAZ4C-	8 (Gray)	2
#3 AWG #2 Sol.	YAZ3C-	9 (White)	2
#2 AWG Code & Flex	YAZ2C- YAZV2C-	10 (Brown)	2



### Specifications:

Size:	10.50" x 3.00" x 1.00"
Weight:	1.3 lbs
Die Style:	Rotating Die Wheel
Warranty:	5 year limited warranty

### Variations:

**Y122CMRKIT** Contains Y122CMR tool in sturdy metal carrying case and select terminals below:  
YAV102TC14, YAZV10TC14, YAZV102TC14,  
YAZ8CTC14, YAZ8C2TC38, YAZ6CTC14,  
YAZ6C2TC14, YAZV6C2TC14FX, YAZ6C2TC38,  
YAZ6C2TC38SLBOX500, YAZ4C2TC38,  
YAZ3C2TC14, YAZ3C2TC38SLBOX500,  
YAZ2C2TC38, YAZV2C2TC14FX,  
YAZ2C2TC38SLBOX500



Y122CMRKIT includes metal carrying case and select terminals

# Tooling

## Crimpers — Mechanical & Ratchet



### M8ND

#### Full Cycle Ratchet

Hand-held tools for #26 - #8 AWG Terminals/Splices

- Ratchet mechanism does not allow handles to open until full cycle is complete
- Fully protected ratchet mechanism
- Uses standard BURNDY N style dies (sold separately)
- Easy groove identification with color coded dies

#### For Use On:

##### #26 - #8 AWG Terminals/Splices

**Terminal Types:** YAD, BA-E, YAD-F, BA-EF, YAE, BA-ES, YAE-F, BA-EZ, YAE-Z, BA-EL, YAES, YAEV-H, YAEV-L, YAV, YAV-F, YAV-H, YAV-H-F

**Splice Types:** YSV, YSM, YSV-H, YRV-L



*M8ND shown with N8CT die set installed. (Dies sold separately.)*

#### Specifications:

<b>Weight:</b>	1.8 lbs
<b>Size:</b>	10.88" x 2.00" x .88"
<b>Die Style:</b>	N style
<b>Cycles:</b>	10,000
<b>Warranty:</b>	5 year limited warranty

## MRC840 Series

### Mechanical Rotating Crimp Tool

For #8 - 4/0 AWG Uninsulated (Bare) Terminals/Splices

- Heat treated steel jaws
- Spring loaded mechanism locks die wheel into position
- Multiple crimp selection with rotatable die wheels
- Die index embossment for inspectability

#### For Use On:

##### MRC840

#8 - #4/0 AWG Copper Terminals/Splices

Types: YA, YA-L, YS, YS-L

##### MRC840AL

#8 - #4/0 AWG Aluminum Terminals/Splices

Types: YA-A, YS-A



#### Specifications:

<b>Size:</b>	26.00" x 8.00" x 1.50"
<b>Weight:</b>	8.3 lbs
<b>Die Style:</b>	Rotating Die Wheel
<b>Warranty:</b>	5 year limited warranty

# Tooling

## Crimpers — Mechanical & Ratchet



### MY28/MY29 Series

#### Dieless Mechanical Compression Tools

#8 Str. - 250 kcmil Copper; #8 Str. - 4/0 Str. Aluminum

- Easy to adjust nest die with knurled steel knob and machine threads
- Rugged tool design with heavy duty forged steel with reinforced back and handles
- Bench mount adapter (sold separately) available

#### For Use On:

##### MY29-3, MY29-3C (covered handles), MY29-3CF (fully covered)

#8 Str. - 250 kcmil Copper commercial (code) cable

30 Navy - 250 Navy Copper Navy cable

#8 Str. - 4/0 Str. Aluminum commercial (code) cable

Types (Copper): YA, YA-L, YS-L

Types (Aluminum): YA-A, YS-A

##### MY29-11, MY29-11C (covered handles), MY29UNIVERSALKIT (MY29-11 tool with select connectors)

#8 Str. - 250 kcmil Copper commercial (code) cable

30 Navy - 250 Navy Copper Navy cable

#8 Str. - 4/0 Str. Flexible copper mine machine cable

Types (Copper): YA, YA-L, YS, YAV-FX, YS-L,

YAV-L, YSV-L

##### MY28

#8 Str. - 4/0 Str. Copper aircraft cable

Types (Copper): YAV-L, YSV-L

##### MY28-4

#8 Str. - 4/0 Str. Aluminum aircraft cable

Types (Aluminum): YAV-A-L, YSV-A-L, YAV-A-R

##### MY28-6

#8 Str. - 2/0 Str. Copper aircraft cable (flexible)

Types (Copper): Nylon Insulated: YAE-L, YAEV-RS,

YAEV-H, YAEV-RH



#### Specifications:

Weight:	8.0 lbs
Size:	22.65" x 4.88" x 1.12"
Die Style:	Dieless
Cycles:	10,000
Warranty:	5 year limited warranty

#### Accessories:

BMV-BCH-MT: Bench Mount Adapter

*Close-up of dieless mechanism*



US: 1-800-346-4175 / International: 1-603-647-5299 / Canada: 1-800-387-6487 / [www.burndy.com](http://www.burndy.com)



**OH25****Dieless Full Cycle Ratchet**

Installs Service Entrance Splice Connectors #10 - 1/0

- Ratchet mechanism does not allow handles to open until full cycle is complete
- Easy, one-hand operation incrementally closes jaws with each handle stroke
- Spring-loaded comfort grip handles
- Forged steel jaws and stainless steel indentor

**For Use On:****Conductor Range: #10 - 1/0**

5/8" Service Entrance Sleeves:

INSULINK™ Type ES (insulated) #10 - 1/0 Str.

LINKIT™ Type YSU (bare) #8 - 1/0 Str.

5/8" Neutral Tension Sleeves HYSPLICE™

Types: YS-S, YCS-R, YDS-AT (#4 - 1/0)

AYP Type HYPLUG™ #6 - 1/0 Str.

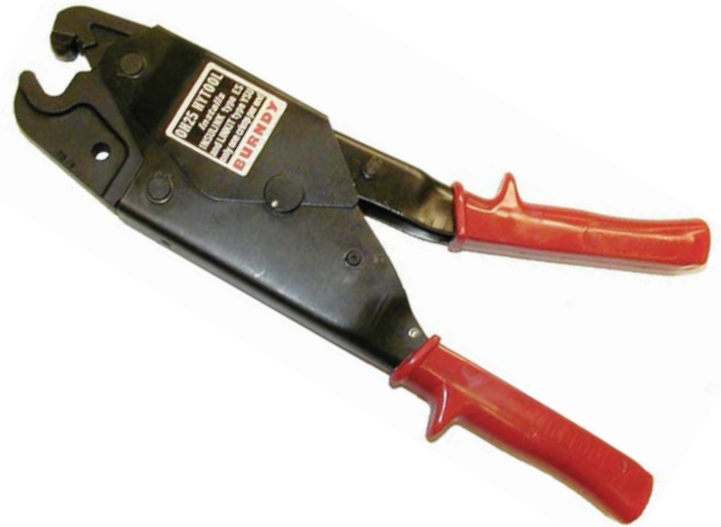
**Specifications:**

<b>Handle Force:</b>	50 lbs. max.
<b>Force Developed:</b>	6,000 lbs max.
<b>Size:</b>	12.25" x 3.75" x 1.50"
<b>Weight:</b>	2 lbs. 11 oz.
<b>Die Style:</b>	Dieless
<b>Warranty:</b>	5 year limited warranty



**PT4583** Leather Holster  
(sold separately)

**Accessories:**

<b>PT4583:</b>	Leather Holster
<b>PT8504:</b>	Go/No-Go Gauge; used to check crimp dimensions

# Tooling

## Crimpers — Mechanical & Ratchet



# OUR840

## 840 POPPER™ HYTOOL™

Overhead/Underground Applications; Full Cycle Ratchet

- Allows proper crimping of sleeves/terminations in underground applications
- Uses X dies for reduced handle force and W dies for fewer number of crimps
- UL Listed connections when used with BURNDY Listed connectors and color-coded X dies

**For Use On:** See charts for details

### Selected Applications

Copper conductors #8 AWG - 250 kcmil

Aluminum conductors #8 AWG to 4/0 AWG

Copper Terminals & Splices					
Copper Wire Size	Connector Catalog Types	Die	Die Index # (Color)	# Crimps per Barrel Length	
				Std	Long
#8 AWG Str.	YA8C-, YS8C-	X8CRT	49 (Red)	1	2
#6 AWG Str.	YA6C-, YS6C-	X5CRT	7 (Blue)	1	2
#5 AWG Str.	YA5C-, YS5C-				
#4 AWG Str.	YA4C-, YS4C-	X4CRT	8 (Gray)	1	2
#2 AWG Str.	YA2C-, YS2C-	X2CRT	10 (Brown)	1	2
#1 AWG Str.	YA1C-, YS1C-	X1CRT	11 (Green)	1	2
1/0 AWG Str.	YA25-, YS25-	X25RT	12 (Pink)	2	4
2/0 AWG Str.	YA26-, YS26-	X26RT	13 (Black)	2	4
3/0 AWG Str.	YA27-, YS27-	X27RT	14 (Orange)	3	6
4/0 AWG Str.	YA28-, YS28-	X28RT	15 (Purple)	3	6
250 kcmil	YA29-, YS29-	X29RT	16 (Yellow)	4	8

### Accessories:

- XOH25:** Nest/Indenter die set for OUR840
- W28K:** Cutter die for #4 - 4/0 ACSR, Copper, Aluminum
- PT4583:** Leather Holster made from top grain cowhide saddle leather with large grommet
- OUR840-WC:** Metal carrying case with die tray - holds OUR840 tool and up to eleven (11) X dies (sold separately)



### Specifications:

- Handle Force:** 8 lbs max.
- Force Developed:** 8,000 lbs.max.
- Die Style:** W and X style dies
- Size:** 13.00" x 3.75" x 1.50"
- Weight:** 2 lbs. 14 oz.
- Warranty:** 5 year limited warranty

Aluminum Terminals & Splices				
Aluminum Wire Size	Connector Catalog Types	Die	Die Index # (Color)	# Crimps
#8 AWG Str.	YA8CA-, YS8CA	X8CART	374 (Blue)	2
#6 AWG Str.	YA6CA-, YS6CA	X6CART	346 (Gray)	2
#4 AWG Str.	YA4CA-, YS4CA-	X4CART	375 (Green)	3
#2 AWG Str.	YA2CA-, YS2CA-	X2CART	348 (Pink)	4
#1 AWG Str.	YA1CA-, YS1CA-	X1CART	471 (Gold)	3
1/0 AWG Str.	YA25A-, YS25A-	X25ART	296 (Tan)	4
2/0 AWG Str.	YA26A-, YS26A	X26ART	297 (Olive)	4
3/0 AWG Str.	YA27A-, YS27A-	X27ART	467 (Ruby)	4
4/0 AWG Str.	YA28A-, YS28A-	X28ART	298 (White)	6

### MD6 Series

#### Hand-Operated HYTOOL™

Installs full range of connectors #14 - 4/0

- Uses BURNDY® W dies
- Spring loaded positive lock die retainer buttons
- Multiple variations available

#### For Use On:

Copper, Aluminum, ACSR, Steel, Copperweld, Alumoweld, 6201, 5005, Compressed, and Compact Conductors

#### Taps:

Copper: #10 sol. to 2/0 str.

Aluminum & ACSR: #14 sol. to 4/0 ACSR

#### Stirrups:

#6 to 4/0 ACSR

#### Overhead Full Tension Deadends, Full Tension Splices and Terminals:

#10 str. to 4/0 ACSR

#### Installs Splices, Taps or Terminations:

#8 to 500 kcmil Copper Stranded (YA, YA-L, YS, YS-L)

#8 to 350 kcmil Copper Flex

#8 to 350 kcmil Aluminum (YA-A, YS-A)

#### Variations:

- MD6** Permanent BG (5/8) and D3 grooves; with WO die (sold separately) can install the CABLELOK CRIMPIT™ and HYCRIMP™ tap connectors
- MD6-8** Permanent O and D3 grooves; with WBG die (sold separately) can install the CABLELOK CRIMPIT™ and HYCRIMP™ tap connectors
- MD6-6** Snub-nose, permanent D3 groove only
- MD6-37** Permanent 161, 162, 163, 171 dies in jaw (J, M & P, T & X)
- MD6-38** Permanent K, BG, C dies in jaw
- MD6-K** Snub-nose, accepts KEARNEY™ type O dies; using KWADP adapter (sold separately) will accept BURNDY W and X dies

**Hotstick Tools Available - Contact Customer Service**



#### Specifications:

<b>Crimp Force:</b>	9,000 lbs
<b>Life Cycle:</b>	Tested over 90,000 cycles with no adjustments or part replacement
<b>Length:</b>	25.50" x 4.50" x 2.00"
<b>Weight:</b>	6.0 lbs
<b>Die Style:</b>	W and X styles
<b>Warranty:</b>	5 year limited warranty

#### Variations (continued):

- MD6-4** Permanent BG (5/8) and D3 grooves; straight fiberglass handles 24" long; fiberglass rated 100kV per foot for 5 min.
- MD6-14** Permanent BG (5/8) and D3 grooves; straight fiberglass handles 19" long with grips; fiberglass rated 100kV per foot for 5 min.
- MD6-12** Permanent O and D3 grooves; straight fiberglass handles 24" long; fiberglass rated 100kV per foot for 5 min.

#### Accessories:

- W-BG:** Common die set for MD6-8, MD6-12
- W-O:** Common die set for MD6, MD6-4, MD6-14
- KWADP:** Adapter to use BURNDY W and X dies with MD6-K variation
- WDIETREE:** W die holder for 6 die sets

# Tooling

## Crimpers — Mechanical & Ratchet



### MD7 Series

#### Hand-Operated HYTOOL™

Installs full range of connectors #14 - 4/0

- Accepts W and X Dies
- Ergonomic, one-piece composite polymer handles
- Nickel plated jaws and jaw links

#### For Use On:

Copper, Aluminum, ACSR, Steel, Copperweld, Alumoweld, 6201, 5005, Compressed, and Compact Conductors

#### Taps:

Copper: #10 sol. to 2/0 str.

Aluminum & ACSR: #14 sol. to 4/0 ACSR

#### Stirrups:

#6 to 4/0 ACSR

#### Overhead Full Tension Deadends, Full Tension Splices and Terminals:

#10 str. to 4/0 ACSR

#### Installs Splices, Taps or Terminations:

#8 to 500 kcmil Copper Stranded (YA, YA-L, YS, YS-L)

#8 to 350 kcmil Copper Flex

#8 to 350 kcmil Aluminum (YA-A, YS-A)

#### Variations:

**MD7** Permanent BG (5/8) and D3 grooves; with WO die (sold separately) can install the CABLELOK CRIMPIT™ and HYCRIMP™ tap connectors

**MD7-8** Permanent O and D3 grooves; with WBG die (sold separately) can install the CABLELOK CRIMPIT™ and HYCRIMP™ tap connectors

**MD7-6** Snub-nose, permanent D3 groove only



#### Specifications:

<b>Output Force:</b>	4 Tons
<b>Size:</b>	25.00" x 4.50" x 2.00"
<b>Weight:</b>	7.0 lbs.
<b>Die Style:</b>	W and X styles
<b>Life Cycle:</b>	Tested over 90,000 cycles with no adjustments or part replacement
<b>Warranty:</b>	5 year limited warranty

#### Accessories:

<b>W-BG:</b>	Common die set for MD7-8
<b>W-O:</b>	Common die set for MD7, MD7-6
<b>WDIETREE:</b>	W die holder for 6 die sets

# MD7-34R

## Hand-Operated POSI-PRESS™

Hand-operated full cycle ratchet tool

- Full stroke ratchet mechanism
- Ergonomical one-piece composite polymer handles
- Allows use of complete W-VT, W-RT and X-RT line of BURNDY dies with die embossment

### For Use On:

#### Copper Lugs/Splices #8 - 500 kcmil:

Types: YA, YA-L, YA-L-TC, YA-L-NT, YS-L, YS, YST, YA-TC

#### Copper Lugs/Splices #8 - 350 kcmil Flex

Types: YAV-L-TC-FX, YA-LB, YA-TC-FXB, YSV-L, YAV-L-NT-FX, YAV-L-FX, YAV-FXB

#### Copper Battery Lugs #8 - 350 kcmil Flex

Type: YAG-TC-LD

#### Thin Wall C-Taps #12 - 3/0 AWG

Type: YC-L

### Variations:

<b>MD7-34R-C</b>	MD7-34R tool with EPDM rubber covering
<b>MD7-34R-KIT1</b>	MD7-34R tool, metal carrying case and all dies for #8 - 500 kcmil copper HYDENT™ and C-Taps for #12 - 3/0 AWG
<b>MD7-34</b>	Supplied <u>without</u> the ratchet mechanism
<b>MD7-34-KIT1</b>	MD7-34 tool (no ratchet mechanism), metal carrying case and all dies for #8 - 500 kcmil copper HYDENT™ and C-Taps for #12 - 3/0 AWG



### Specifications:

<b>Crimp Force:</b>	9,000 lbs
<b>Length:</b>	26.00" x 4.50" x 2.00"
<b>Width:</b>	8.00" at handles; 4.50" at jaws
<b>Die Style:</b>	W-VT, W-RT, and X-RT Styles
<b>Handle Material:</b>	Reinforced composite polymer
<b>Warranty:</b>	5 year limited warranty

### Accessories:

<b>PT4952-1:</b>	Metal carry case
<b>PT4925:</b>	Canvas bag
<b>WDIETREE:</b>	W die holder for 6 sets of dies

# OEM840NCP

## OEM Pneumatic Press

Installs #8 - 4/0 AWG

- Customizable clear safety guard for left, right, or front feed cable entry
- Guarded foot switch
- Adjustable connector locator
- Cycle counter
- Accommodates UM, U and W dies
- Testing for UL Listing performed up to:
  - U dies: UL Listed to 1/0 AWG (YA-L), #2 AWG (YAV-L)
  - W dies: UL Listed to 3/0 AWG (YA-L), 1/0 AWG (YAV-L)

### Accessories:

- PT50024685:** U / UM Die Holder Assembly  
**PT50024683:** W Die Holder Assembly  
**PT50024605:** Front Safety Guard

See Connector and Die Selection Matrix below  
 all dies, nest and indenters are sold separately



### Specifications:

- Weight:** 60.0 lbs  
**Size:** 22.75" x 12.38" x 10.25"  
 (18.56" L with air gauge)  
**Die Style:** UM, U, W Styles  
**Crimp Speed:** 3 seconds (approximately)  
**Life Cycles:** 2.5 M cycles (min)  
**Air Pressure:** 90-100 PSI  
**Connector Port:** 3/8" NPT female thread  
**Warranty:** 2 year limited warranty

Connector and Die Selection Matrix				
Wire Size	YAD-M Connectors		YA and YA-L Connectors	
	UM Dies (DLO Copper)		U Dies (Code)	W Dies (Code)
	Indenter	Nest	Copper	Copper
#8 AWG	UMA	UM8CN	U8CRT	W8CRT
#6 AWG	UMB	UM6CN	U6CRT	W6CRT
#4 AWG	UMB	UM4CN	U4CRT	W4CRT
#2 AWG	UMB	UM2CN	U2CRT	W2CRT
1/0 AWG	UMC	UM25N	U25RT	W25RT
2/0 AWG	UMC	UM26N	U26RT	W26RT
3/0 AWG	UMC	UM27N	U27RT	W27RT
4/0 AWG	UMC	UM28N	U28RT	W28RT



UM Nest/Indenter



UM Crimped Terminal

# Y6NCP1

## Pneumatic OEM Crimp Tool

Accepts J-dies for wider wire range

- UL Listed connections used with BURNDY UL Listed connectors
- 360° rotating head
- Reliable crimp performance
- Tested to 300,000 crimps without a failure
- Pull Out Force exceeds Mil Spec/SAE\*

### For Use On:

#### Copper - #22 - #4 AWG

Nylon, Vinyl and Bare Terminals/Splices

#### Nylon:

YAE, YAE-N, YAE-N-F, YAE-Z, YAEV, YAEV-L, YAEV-H, YAEV-RH, YAEV-RS, TN\*, YAES\*, TN-F\*, YAES-F\*, SN, YSE-HN

#### Vinyl:

TP, BA, TP-F, BA-EF, TP-Z, BA-EZ, TP-LF, BA-EL, SP, BS

#### Bare:

T, YAD, T-F, YAD-F, YAV, YAV-L, YAV-H, YAV-R, YAV-RS, YAV-T-F, YAV-H-F, YAV-Z, YSV, YSV-H, YSV-L, YA, YAV, YS, YSV

\*Excludes TN and YAES terminals with #12 AWG wire

### Pneumatic crimp tool Y6NCP1 includes:

Y6NCP1 Tool  
Tool Case  
1/8" NPT air hose  
Crimp head for J-Dies

### Variations:

**Y6NCP1SD** Pneumatic OEM Tool using SD-dies (industry standard profile); See separate cut sheet for more information



### Specifications:

<b>Tool Weight:</b>	4.4 lbs
<b>Length x Dia.:</b>	12.88" x 2.63" x 2.63"
<b>Die Style:</b>	J style
<b>Air Pressure:</b>	90-110 PSI
<b>Crimp Motion:</b>	Scissor Action
<b>Pull Out Force:</b>	Exceeds Mil Spec/SAE*
<b>Warranty:</b>	1 year limited warranty

### Accessories:

<b>Y6NCP1FTSW:</b>	Foot Switch
<b>Y6NCP1BMNT:</b>	Bench Mount Unit
<b>J6NCP1CH:</b>	Replacement J-die crimp head (included)
<b>J1022NC1:</b>	Die set for YAE, YAE-N, YAE-N-F, YAE-Z
<b>J1022NC2:</b>	Die set for YAEV, YAEV-L, YAEV-H, YAEV-RH, YAEV-RS
<b>J1022NC3:</b>	Die set for TN, YAES, TN-F, YAES-F, SN, YSE-HN
<b>J1022NC4:</b>	Die set for TP, BA, TP-F, BA-EF, TP-Z, BA-EZ, TP-LF, BA-EL, SP, BS
<b>J1022NC5:</b>	Die set for T, YAD, T-F, YAD-F, YAV, YAV-L, YAV-H, YAV-R, YAV-RS, YAV-T-F, YAV-H-F, YAV-Z, YSV, YSV-H, YSV-L
<b>J8CNC:</b>	Die set used with Y2CNC (sold separately) for #8 size YA, YAV, YS, YSV
<b>J6CNC:</b>	Die set used with Y2CNC (sold separately) for #6 size YA, YAV, YS, YSV
<b>J4CNC:</b>	Die set used with Y2CNC (sold separately) for #4 size YA, YAV, YS, YSV
<b>Y2CNC:</b>	Used with J8CNC, J6CNC, and J4CNC (sold separately)

# Tooling

## Crimpers — OEM



# Y6NCP1SD

## Pneumatic OEM Crimp Tool For Loose Piece Terminals/Splices

- UL Listed connections used with BURNDY® UL Listed connectors
- 360° rotating head
- Reliable crimp performance
- Tested to 300,000 crimps without a failure
- Pull Out Force exceeds UL 486A/B
- Industry standard die envelope; identical to MRE1022B and MRE1022NV hand tools crimp profiles

### For Use On:

#### Copper - #22 - #10 AWG

Nylon, Vinyl and Bare Terminals/Splices

#### Nylon:

YAE, YAE-N, YAE-N-F, YAE-Z, YAEV, YAEV-L, YAEV-H, YAEV-RH, YAEV-RS, TN, YAES, TN-F, YAES-F, SN, YSE-HN

#### Vinyl:

TP, BA, TP-F, BA-EF, TP-Z, BA-EZ, TP-LF, BA-EL, SP, BS

#### Bare:

T, YAD, T-F, YAD-F, YAV-, YAV-L, YAV-H, YAV-R, YAV-RS, YAV-T-F, YAV-H-F, YAV-Z, YSV, YSV-H, YSV-L

### Pneumatic crimp tool Y6NCP1SD includes:

- Tool Case
- 1/8" NPT air hose
- Crimp head for SD-Dies
- Nylon/Vinyl SD Die Set
- Bare SD Die Set
- Terminal Locator Plate

### Variations:

- Y6NCP1** Pneumatic OEM Tool using J-dies (sold separately)  
See separate cut sheet for more information



### Specifications:

<b>Tool Weight:</b>	4.4 lbs
<b>Length x Dia.:</b>	12.88" x 2.63" 2.63"
<b>Die Style:</b>	SD Industry-Standard Die Envelope
<b>Air Pressure:</b>	90-110 PSI
<b>Crimp Motion:</b>	Scissor Action
<b>Pull Out Force:</b>	Exceeds UL 486A/B
<b>Warranty:</b>	1 year limited warranty

### Accessories:

<b>Y6NCP1FTSW:</b>	Foot Switch
<b>Y6NCP1BMNT:</b>	Bench Mount Unit
<b>SD10NCP1CH:</b>	Replacement SD-die crimp head (included)
<b>BECNVSD:</b>	Replacement Nylon/Vinyl SD-die set (included)
<b>BECBSD:</b>	Replacement Bare SD-die set (included)
<b>SD10NCP1LP1:</b>	Replacement Locator Plate (included)



Spring-loaded Terminal Locator



**Y6NCP1BMNT**  
(tool not included  
sold separately)



# Y46OEM12T

## 12 Ton Remote Operated HYPRESS™ Designed for OEM Applications, Bench Mounted

- Head mounted at 45° angle
- U dies for copper and aluminum
- Forged steel tool, precision machined components
- Coupler at 90° angle

### For Use On:

#### Copper Terminals (Bare) #6 - 750 kcmil Code/Navy:

Types: YA, YA-2N, YA-L, YA-LB, YA-TC, YA-2LN, YAB-4N, YAV-L, YAV-RS, YA-TC-FX

#### Copper Terminals (Insulated) #8 - 2/0 Flex/Extra Flex

Types: YAEV-L, YAEV-H, YAEV-RS, YAEV-RH

#### Aluminum Terminals #6 - 750 kcmil Code

Types: YA-A, AYP, AYPO

### Variations:

<b>Y46OEM12TKIT</b>	Kit complete with Y46OEM12T tool, Y8AC9 pump, and PT29900-10 hose
<b>Y46OEM12TKITFC</b>	Kit complete with Y46OEM12TKIT (see above) and YACFC foot switch
<b>Y46OEM12TKIT1</b>	Kit complete with Y46OEM12TKIT (see above), Y46OEMGUARD, Y46OEMLOCATOR, and 12TONP1
<b>Y46OEM12TKIT1FC</b>	Kit complete with Y46OEM12TKIT1 (see above) and YACFC foot switch



### Specifications:

<b>Operating Pressure:</b>	8,800 PSI
<b>Force Developed:</b>	12 Tons
<b>Weight:</b>	34.5 lbs
<b>Size:</b>	14.00" x 12.25" x 10.00"
<b>Die Style:</b>	U Dies (with PUADP-1 adapter, included)
<b>Warranty:</b>	5 year limited warranty

### Accessories:

<b>Y8AC9:</b>	5/8 HP Electric Hydraulic Pump 8,800 PSI
<b>PT29900-10:</b>	10 foot long hydraulic hose
<b>YACFC:</b>	Foot switch for Y8AC9 pump
<b>Y46OEMGUARD:</b>	Clear safety shield
<b>Y46OEMLOCATOR:</b>	Adjustable connector locator
<b>12TONP1:</b>	Factory installed stroke limiter
<b>UDIEKITCU:</b>	U die kit complete with 15 U die sets for crimping #6 AWG - 750 kcmil copper, provided in one metal storage case
<b>UDIEKITAL:</b>	U die kit complete with 15 U die sets for crimping #6 AWG - 750 kcmil aluminum, provided in one metal storage case

# Y46OEM11T

## 11 Ton Remote Operated HYPRESS™ Designed for OEM Applications, Bench Mounted

- Same crimp profile as 644 Series tools with dedicated P644 die set permanently affixed
- “1 Crimp” technology for most long and standard length barrel terminals
- Expanded range taking capacity

### For Use On:

#### Copper Terminals #6 - 750 kcmil Code/Navy (Terminals):

Types: YA-L, YA-2LN, YA, YA-2N, YA-L-2TC,  
YAB-4N, YA-L-TC, YA-2L, YA-4N

#### Copper Terminals #6 - 500 kcmil Code/Navy (Splices):

Types: YS-L, YS-T, YS

#### Aluminum #6 - 500 kcmil

Terminal Types: YA-A, YA-A-TN  
HYPLUG™ Types: AYP, AYPO

#### Aluminum #6 - 350 kcmil

Splice Type: YS-A

### Variations:

**Y46OEM11TKIT** Kit complete with Y46OEM11T tool, Y7AC9 electric pump (7,300 PSI), and PT29900-10 10' hydraulic hose

### NOTE:

Not to be used with 10,000 PSI operating pressure.  
Ensure ONLY 7,300 PSI is used for this 11-Ton output force tool.



### Specifications:

Operating Pressure:	7,300 PSI
Force Developed:	11 Tons
Weight:	34.5 lbs
Size:	14.00" x 12.25" x 10.00"
Die Style:	P644 die permanently affixed
Warranty:	5 year limited warranty

### Accessories:

<b>Y7AC9:</b>	7,300 PSI Electric Hydraulic Pump
<b>PT29900-10:</b>	10 foot long hydraulic hose
<b>Y46OEMGUARD:</b>	Clear safety shield
<b>Y46OEMLOCATOR:</b>	Adjustable connector locator

# Y29NC

## Hand Operated Pneumatic HYPRESS™ For #8 - 2/0 copper; insulated and bare terminals

- Portable or bench mountable
- Adjustable blow off valve
- D type nest dies with Y29 type indenters

### For Use On:

#### Copper #8 - 2/0

Types: YAEV-L, YAEV-H, YAEV-RS, YAEV-RH, YAV-L, YAV-R, YAV-RS, YSV-L, YSM

### Die Information:

Die Information		
Nest	Indenter	Die Index
DV8L	Y29PL	38/631, 6/631, 49
DV6L	Y29PL	39/632
D6CL	Y29PR	7
DV4L	Y29PL	40/633
D3CL	Y29PR	9
DV2CL	Y29PL	41/634
DV1L	Y29PL	42
DV25L	Y29PL	43
DV26L	Y29PL	44



### Specifications:

Air Line Pressure:	85 - 100 PSI
Die Style:	D style nest with Y29 type indenter
Length:	17.50" x 5.00" x 5.00"
Weight:	12.5 lbs
Warranty:	5 year limited warranty

### Accessories:

DV8L:	Nest Die for use with Y29PL indenter
DV6L:	Nest Die for use with Y29PL indenter
D6CL:	Nest Die for use with Y29PR indenter
DV4L:	Nest Die for use with Y29PL indenter
D3CL:	Nest Die for use with Y29PR indenter
DV2CL:	Nest Die for use with Y29PL indenter
DV1L:	Nest Die for use with Y29PL indenter
DV25L:	Nest Die for use with Y29PL indenter
DV26L:	Nest Die for use with Y29PL indenter
Y29PL:	Indenter for use with DV style dies
Y29PR:	Indenter for use with D-L style dies

**12-Ton U Dies\***

**For Y35, Y39, Y750, PAT750 Series  
PAT46 Series (with PUADP-1 Adapter)**

\* Non-tension U-type 12 ton dies for YA, YS, YA-A, YS-A style connectors

\*\* Wide dies are intended for use on long barrel terminals and splices (YA/YS) only.



*U28RT Die Set*

Die Sets sold separately; U Die Kits also available; see following page

Note: N/A = not applicable

Wire Size	Copper	Copper Wide Die**	Aluminum
#8 AWG	U8CRT	U8CRTW	U8CABT
#6 AWG	U5CRT	U5CRTW	U6CABT
#4 AWG	U4CRT	U4CRTW	U4CABT
#3 AWG	U3CRT	U3CRTW	N/A
#2 AWG	U2CRT	U2CRTW	U2CABT
#1 AWG	U1CRT-1	U1CRT-1W	U1CART
1/0 AWG	U25RT	U25RTW	U25ART
2/0 AWG	U26RT	U26RTW	U26ART
3/0 AWG	U27RT	U27RTW	U27ART
4/0 AWG	U28RT	U28RTW	U28ART
250 kcmil	U29RT	N/A	U29ART
300 kcmil	U30RT		U30ART
350 kcmil	U31RT		U31ART
400 kcmil	U32RT		U32ART
500 kcmil	U34RT		U34ART
535 Flex	U38XRT		N/A
600 kcmil	U36RT		U36ART
750 kcmil	U39RT		U39ART-2
777 Flex	U44XRT		N/A



*U5CRTW Wide Die Set*



*PT29291 die box is available (sold separately) holding up to 15 "U" style (standard or wide) die sets; dies not included.*

# U Die Kits

For Y35, Y39, Y750, PAT750 Series  
PAT46 Series (with PUADP-1 Adapter)

**UDIEKITCU** and **UDIEKITAL** include 15 sets of “U” dies and die case. These stainless steel color coded dies are for crimping YA, YS, YA-A, and YS-A types of connectors, ranging from #6 AWG through 750 kcmil.

**UDIEKITCUW** includes 9 sets of wide stainless steel color coded dies for crimping long barrel YA and YS types of connectors up to 4/0 AWG. The wide dies require only one crimp compared to 2 for the standard width dies.

UDIEKITCU



Note: N/A = not applicable

Wire Size	UDIEKITCU includes	UDIEKITCUW includes	UDIEKITAL includes
#8 AWG	N/A	U8CRTW	N/A
#6 AWG	U5CRT	U5CRTW	U6CABT
#4 AWG	U4CRT	U4CRTW	U4CABT
#2 AWG	U2CRT	U2CRTW	U2CABT
#1 AWG	U1CRT-1	U1CRT-1W	U1CART
1/0 AWG	U25RT	U25RTW	U25ART
2/0 AWG	U26RT	U26RTW	U26ART
3/0 AWG	U27RT	U27RTW	U27ART
4/0 AWG	U28RT	U28RTW	U28ART
250 kcmil	U29RT	N/A	U29ART
300 kcmil	U30RT		U30ART
350 kcmil	U31RT		U31ART
400 kcmil	U32RT		U32ART
500 kcmil	U34RT		U34ART
600 kcmil	U36RT		U36ART
750 kcmil	U39RT		U39ART-2
Die Case	PT29291	PT29291	PT29291

**UDIEKITHYGRD** includes 8 dies sets. Seven die sets are used to install the BURNDY® HYGROUND® irreversible compression grounding connectors; the U2CABT die set is for pre-crimping 1/2”, 5/8” and 3/4” ground rods for increased rotational resistance. The UDIEKITHYGRD also includes the PT29291 die case.

UDIEKITHYGRD includes
UC, UO, U997, PU998, U1011, U1104, U1105, U2CABT (Ground rod pre-crimp die), and PT29291 die case

# W Dies

**For MD6, MD7, Y500CTHS, PAT600 and PATMD6 Series of tools**

\* These sizes (250 - 500) for Y500CTHS, MD7-34, and MD7-34R only.

\*\* For PAT600 series and Y500CTHS only.

Note: N/A = not applicable

Suitable for use on YA, YS, YA-A, YS-A type non-tension connectors.

Die Sets sold separately; W Die Kits also available; see following page



*W25RT Die Set*

Wire Size	Copper (-VT)	Copper (-RT)	Aluminum
#8 AWG	W8CVT	W8CRT	X8CART
#6 AWG	W5CVT	W5CRT	W161
#4 AWG	W4CVT	W4CRT	W162
#3 AWG	W3CRT	W3CRT	N/A
#2 AWG	W2CVT	W2CRT	W239
#1 AWG	W1CVT	W1CRT-1	W163
1/0 AWG	W25VT	W25RT	W241
2/0 AWG	W26VT	W26RT	W245
3/0 AWG	W27VT	W27RT	W166
4/0 AWG	W28VT	W28RT	W660
250 kcmil	W29VT*	W29RT*	W249
300 kcmil	W30VT*	W30RT*	N/A
350 kcmil	W31VT*	W31RT*	W31ART*
400 kcmil	W32VT*	W32RT*	N/A
450 kcmil	W33VT*	W33RT*	N/A
500 kcmil	W34VT*	W34RT*	N/A
600 kcmil	N/A	W36RT**	N/A

VT = "V" profile die for reduced handle force when using MD6/MD7 series tools; Twin die (includes both halves)  
RT = Round die (circumferential); Twin die (includes both halves)



**WDIETREE** available (sold separately); holds up to 6 "W" style die sets (dies not included); shown with W-BG die set (not included)



**CASEWDIES** die box available (sold separately); holds up to 12 "W" or "X" style die sets (dies not included)

# W Die Kits

**For MD6, MD7, Y500CTHS, PAT600 and PATMD6 Series of tools**

\* These sizes (250 - 500) for PAT600 Series, Y500CTHS, MD7-34, and MD7-34R only.

Note: N/A = not applicable

Suitable for use on YA, YS, YA-A, YS-A type non-tension connectors.



**CASEWDIES**  
included with die kits;  
also sold separately  
(dies not included)

Wire Size	WDIEKITCU for Copper includes	WDIEKITAL for Aluminum includes
#8 AWG	W8CRT	X8CART
#6 AWG	W5CRT	W161
#4 AWG	W4CRT	W162
#2 AWG	W2CRT	W239
#1 AWG	W1CRT-1	W163
1/0 AWG	W25RT	W241
2/0 AWG	W26RT	W245
3/0 AWG	W27RT	W166
4/0 AWG	W28RT	W660
250 kcmil	W29RT*	W249
350 kcmil	W31RT*	W31ART*
500 kcmil	W34RT*	N/A
Die Case	CASEWDIES	CASEWDIES

# Tooling

## Cutters — Battery Actuated



### PATCUT2156-LI

**Latch Head, ACSR up to 2156 kcmil**  
Hydraulic Self-Contained Cutter, 18V Lithium-Ion

- 180° head rotation
- Durable hardened steel blades
- Specialized latch head for mid-span cuts
- Mechanical ram release with no power consumption
- Includes 2 batteries, charger, and polymer carrying case

#### For Use On:

<b>Copper/Aluminum Cable:</b>	up to 2"
<b>ACSR:</b>	up to 2156 kcmil
<b>Ground Rod:</b>	up to 3/4"
<b>Rebar:</b>	up to 5/8"
<b>Soft Steel Bolts:</b>	up to 3/4"
<b>Standard Guy:</b>	up to 9/16"
<b>EHS Guy:</b>	up to 9/16"

#### Variations:

<b>PATCUT2156-LI</b>	18V Lithium-Ion
<b>PATCUT2156-LIDC</b>	PATCUT2156-LI with DC Charger
Ni-MH platform is also available:	
<b>PATCUT2156-18V</b>	Ni-MH battery version
<b>PATCUT2156-18VDC</b>	PATCUT2156-18V Ni-MH tool with 18V DC Charger
<b>PATCUT2156-18V250V</b>	PATCUT2156-18V Ni-MH tool with 250V Charger



#### Specifications:

<b>Output Force:</b>	10 Tons
<b>Tool Weight:</b>	15.5 lbs
<b>Size:</b>	16.50" x 13.50" x 3.38"
<b>Operating Voltage:</b>	18 V-DC Lithium-Ion
<b>Recharge Time:</b>	30 minutes
<b>Warranty:</b>	5 year limited warranty (excluding blades) Lifetime warranty on INFINITY DRIVE® 1 year on batteries and charger

#### Accessories:

<b>BAT18VLI:</b>	Hi-capacity LI battery (3.0 AH)
<b>PATCHGR-LI:</b>	120V-AC Charger
<b>PATCHGR-LIDC:</b>	12/24V-DC Charger
<b>PT208620:</b>	Lanyard
<b>CUT200BLMVBL:</b>	Replacement Moving Blade
<b>CUT200BLSTA:</b>	Replacement Fixed (Stationary) Blade



## PATHCC10-18V

### C-Head, precision cutting blades

Hydraulic Self-Contained Cutter, 18V Ni-MH

- Efficient cable cutting in field and OEM applications
- Interchangeable blades optimized for specific materials
- Available with all blades or variations for with specific blades only
- Includes 2 batteries, charger, and polymer carrying case

#### For Use On:

**Copper/Aluminum Cable:** up to 1.5"

**ACSR/ACSS:** up to 1590 kcmil

**Ground Rod:** up to 5/8"

**Rebar:** up to 1/2"

**Soft Steel Bolts:** up to 5/8"

**Standard/EHS Guy:** up to 9/16"

#### Variations:

<b>PATHCC10-18V</b>	Tool with all blades
<b>PATHCC10C-18V</b>	Covered PATHCC10-18V tool; all blades
<b>PATHCC10-ACSR-18V</b>	PATHCC10-18V tool; only ACSR blades
<b>PATHCC10-CUAL-18V</b>	PATHCC10-18V tool; only CUAL blades
<b>PATHCC10-SOL-18V</b>	PATHCC10-18V tool; only SOL blades
<b>PATHCC10-GUY-18V</b>	PATHCC10-18V tool; only GUY blades
<b>PATHCC10C-ACSR-18V</b>	Covered PATHCC10-18V tool; only ACSR blades
<b>PATHCC10C-CUAL-18V</b>	Covered PATHCC10-18V tool; only CUAL blades
<b>PATHCC10C-SOL-18V</b>	Covered PATHCC10-18V tool; only SOL blades
<b>PATHCC10C-GUY-18V</b>	Covered PATHCC10-18V tool; only GUY blades



#### Specifications:

<b>Output Force:</b>	11 Tons
<b>Tool Weight:</b>	20.4 lbs
<b>Size:</b>	21.50" x 12.88" x 3.75"
<b>Operating Voltage:</b>	18 V-DC Ni-MH
<b>Recharge Time:</b>	45 minutes
<b>Warranty:</b>	5 year limited warranty (excluding blades) Lifetime warranty on INFINITY DRIVE® 1 year on batteries and charger

#### Accessories:

<b>BAT18V:</b>	Hi-capacity Ni-MH battery (2.6 AH)
<b>PATCHGR18V:</b>	120V-AC Charger
<b>BCT/PATDCCHGR:</b>	12/24V-DC Charger
<b>PATCHGR250V:</b>	240/250 V-AC Charger

**Replacement Blades below include screws and wrench for easy installation.**

<b>HCCCUAL:</b>	Copper/Aluminum Cutting Blades
<b>HCCACSR:</b>	ACSR/ACSS Cutting Blades
<b>HCCGUY:</b>	Standard/EHS Guy Cutting Blades
<b>HCCSOL:</b>	Rebar/Ground Rod/Soft Steel Cutting Blades

# Tooling

## Cutters — Battery Actuated



### PATCUT129-LI

**Latch Head, Cu/Al to 1.29" diameter**  
Hydraulic Self-Contained Cutter, 18V Lithium-Ion

- 180° head rotation
- Overmolded handle and ergonomic design
- One-handed operation for advance, retract and hold
- Latch head design for interference free closure for mid-span cuts
- Includes 2 batteries, charger, and polymer carrying case

#### For Use On:

**Copper/Aluminum Cable:** up to 1.29"

**ACSR:** up to 1113 kcmil

**Ground Rod:** up to 5/8"

**Rebar:** up to 1/2"

**Soft Steel Bolts:** up to 5/8"

**Standard Guy:** up to 1/2"

**EHS Guy Strand:** up to 3/8"

#### Variations:

**PATCUT129-LIDC** Tool with 12/24V-DC charger in place of AC charger

Ni-MH platform is also available:

**PATCUT129ACSR-18V** Ni-MH battery version  
**PATCUT129ACSR-18VDC** Ni-MH battery version with 12/24V-DC charger in place of AC charger

**PATCUT129ACSR-18V250V** Ni-MH battery version with 240/250 V-AC Charger



#### Specifications:

**Output Force:** 7 Tons  
**Tool Weight:** 10.2 lbs  
**Size:** 14.50" x 13.50" x 3.50"  
**Operating Voltage:** 18 V-DC Lithium-Ion  
**Recharge Time:** 30 minutes  
**Warranty:** 5 year limited warranty (excluding blades)  
Lifetime warranty on INFINITY DRIVE®  
1 year on batteries and charger

#### Accessories:

**BAT18VLI:** Hi-capacity LI battery (3.0 AH)  
**PATCHGR-LI:** 120V-AC Charger  
**PATCHGR-LIDC:** 12/24V-DC Charger  
**PT208620:** Lanyard  
**PT10037388:** Replacement Moving Blade  
**PT10037384:** Replacement Fixed Blade

# PATCUT245-LI

**Latch Head, Cu/Al up to 2.45" O.D.**  
Hydraulic Self-Contained Cutter 18V Lithium-Ion

- 180° head rotation
- Cuts up to 2.45" diameter copper/aluminum cable
- Specialized latch style cutting head for interference-free closure for mid-span work
- Ergonomic design, overmolded handle
- Includes 2 batteries, charger, and polymer carrying case

## For Use On:

**Copper/Aluminum Cable:**  
Up to 2.45" O.D.

**For Copper and Aluminum cable only. Do not cut steel, ground rod, rebar or guy wire.**

## Variations:

**PATCUT245-LIDC** Tool with 12/24V-DC charger in place of AC charger

Ni-MH platform is also available:

**PATCUT245CUAL-18V** Ni-MH battery version  
**PATCUT245CUAL-18VDC** Ni-MH battery version with 12/24V-DC charger in place of AC charger  
**PATCUT245CUAL-18V250V** Ni-MH battery version with 240/250 V-AC Charger



## Specifications:

<b>Output Force:</b>	6 Tons
<b>Tool Weight:</b>	13.7 lbs
<b>Size:</b>	18.13" x 13.50" x 3.50"
<b>Operating Voltage:</b>	18 V-DC Lithium-Ion
<b>Recharge Time:</b>	30 minutes
<b>Warranty:</b>	5 year limited warranty (excluding blades) Lifetime warranty on INFINITY DRIVE® 1 year on batteries and charger

## Accessories:

<b>BAT18VLI:</b>	Hi-capacity LI battery (3.0 AH)
<b>PATCHGR-LI:</b>	120V-AC Charger
<b>PATCHGR-LIDC:</b>	12/24V-DC Charger
<b>PT208620:</b>	Lanyard
<b>PT10038657:</b>	Replacement Moving Blade
<b>PT10040663:</b>	Replacement Fixed Blade

# Tooling

## Cutters — Battery Actuated



# PATMDCUT-LI

## Battery Actuated IN-LINE® Tool

Hydraulic Self-Contained Cutter 18V Lithium-Ion

- 350° head rotation
- Ergonomically balanced tool design
- Actuated blade guide automatically closes for easy positioning
- Interchangeable scissor action jaws (sold separately) available to crimp or cut with same tool
- Includes 2 batteries, charger, and polymer carrying case

### For Use On:

### Maximum Cutting Capacity:

#### ACSR:

556 kcmil (26/7 Dove)

#### AAC:

636 kcmil

#### Copper:

500 kcmil soft drawn copper

#### Guy Wire:

3/8" Utility and High Strength

**(Not for use on Extra High Strength Conductor)**

### Variations:

PATMDCUT-LI	Tool with cutting blades; 120V-AC Li-Ion charger
PATMDCUT-LIDC	Tool with cutting blades; 12V-DC Li-Ion charger

**Crimp/Cut Kits are also available supplied with both crimping and cutting jaws;** see separate catalog page

Ni-MH platform is also available:

PATMDCUT14V	Ni-MH battery with 120V-AC Ni-MH charger
PATMDCUT14VDC	Ni-MH battery with 12V-DC Ni-MH charger
PATMDCUT14V250V	Ni-MH battery with 250V-AC Ni-MH charger



### Specifications:

Output Force:	6 Tons
Tool Weight:	8 lbs
Size:	22.00" x 5.00" x 2.75"
Operating Voltage:	18 V-DC Lithium-Ion
Recharge Time:	30 minutes
Warranty:	5 year limited warranty Lifetime warranty on INFINITY DRIVE® 1 year on batteries and charger

### Accessories:

BAT18VLI:	Hi-capacity LI battery (3.0 AH)
PATCHGR-LI:	120V-AC Charger
PATCHGR-LIDC:	12/24V-DC Charger
PATMDCUTACSRKIT:	Replaceable ACSR Blades Only (not jaw assembly)
PT10074020:	Wrist Strap

### Interchangeable Jaw Assemblies (no tool included):

PATJAWSCUT:	Cutting Jaws, includes ACSR blades
PATJAWSMD6:	Crimp jaws with permanent BG & D3 die grooves
PATJAWSMD6-8:	Crimp jaws with permanent O & D3 die grooves
PATJAWSMD6-6:	Crimp jaws with permanent D3 die groove only
PATJAWSMD6-K:	Crimp jaws with KEARNEY™ groove

PATMD6JC:	Jaw covers for PATJAWSMD6 & PATJAWSMD6-8
PATMD6-6JC:	Jaw covers for PATJAWSMD6-6
PATMD6-KJC:	Jaw covers for PATJAWSMD6-K

US: 1-800-346-4175 / International: 1-603-647-5299 / Canada: 1-800-387-6487 / www.burndy.com

## PATMD-LLI Series

### PATRIOT® IN-LINE® Pole Cutters

Hydraulic Self-Contained Cutter, 18V Lithium-Ion

- Available in 3 lengths
- One set of blades to cut all specified materials
- Actuated blade guide automatically closes
- Break away guide frees tool by pulling away from conductor
- Interchangeable scissor action jaws (sold separately) available to crimp or cut with same tool

#### For Use On:

#### Maximum Cutting Capacity:

##### ACSR:

556 kcmil (26/7 Dove)

##### AAC:

636 kcmil

##### Copper:

500 kcmil soft drawn copper

##### Guy Wire:

3/8" Utility and High Strength

(Not for use on Extra High Strength Conductor)

#### Variations:

PATMDCUT48L-LI	48" working length
PATMDCUT60L-LI	60" working length
PATMDCUT72L-LI	72" working length

Ni-MH platform is also available:

PATMDCUT48L-NMH	Ni-MH battery version; 48" working length
PATMDCUT60L-NMH	Ni-MH battery version; 60" working length
PATMDCUT72L-NMH	Ni-MH battery version; 72" working length



#### Specifications:

Output Force:	6 Tons
Size:	86.00" x 5.50" x 3.75"
Operating Voltage:	18 V-DC Lithium-Ion
Recharge Time:	30 minutes
Warranty:	5 year limited warranty Lifetime warranty on INFINITY DRIVE® 1 year on batteries and charger

#### Accessories:

BAT18VLI:	Hi-capacity LI battery (3.0 AH)
PATCHGR-LI:	120V-AC Charger
PATCHGR-LIDC:	12/24V-DC Charger
PATMDCUTACSRKIT:	Replaceable ACSR Blades Only (not jaw assembly)
PT10074020:	Wrist Strap

#### Interchangeable Jaw Assemblies (no tool included):

PATJAWSCUT:	Cutting Jaws, includes ACSR blades
PATJAWSMD6:	Crimp jaws with permanent BG & D3 die grooves
PATJAWSMD6-8:	Crimp jaws with permanent O & D3 die grooves
PATJAWSMD6-6:	Crimp jaws with permanent D3 die groove only
PATJAWSMD6-K:	Crimp jaws with KEARNEY™ groove

PATMD6JC:	Jaw covers for PATJAWSMD6 & PATJAWSMD6-8
PATMD6-6JC:	Jaw covers for PATJAWSMD6-6
PATMD6-KJC:	Jaw covers for PATJAWSMD6-K

# Tooling

## Cutters — Battery Actuated



### BCC1000CUAL

#### Sealed Nickel Cadmium Cutter

Cuts up to 750 kcmil hard drawn copper;  
1000 kcmil soft drawn copper; 2" O.D. aluminum

- Hook head design
- Three-way switch
- Hardened steel blades
- Withstands rugged use, resists oil and solvents
- Includes 1 battery, 1 charger, and case

#### For Use On:

##### Hard Drawn Copper:

750 kcmil

##### Soft Drawn Copper:

1000 kcmil

##### Aluminum:

up to 2" O.D

Do Not Cut Steel or ACSR



#### Specifications:

Tool Weight:	6.0 lbs
Size:	14.50" x 4.50" x 4.00"
Operating Voltage:	12 V-DC Nickel Cadmium
Recharge Time:	1 hour (fast) to 16 hours (standard)
Warranty:	90 day limited warranty (excluding blades)

#### Accessories:

BCCBAT12V:	Sealed nickel cadmium battery
BCCCHGR:	120 V-AC Charger
BCCCASE:	Replacement Case for BCC1000CUAL tool
RP50RP03:	Replaceable Moving Blade
RP50RP02:	Replaceable Fixed Blade



# YCUT129ACSR

## Latch Head Style

Hydraulic Hand Operated Cutter

- Rapid advance pump
- Handle trigger drain
- Interference free closure on mid-span cuts
- 180° head rotation

### For Use On:

**Copper/Aluminum Cable:** up to 1.29"

**ACSR:** up to 1113 kcmil

**Ground Rod:** up to 5/8"

**Rebar:** up to 1/2"

**Soft Steel Bolts:** up to 5/8"

**Standard Guy:** up to 1/2"

**EHS Guy Strand:** up to 3/8"



### Specifications:

<b>Output Force:</b>	7 Tons
<b>Weight:</b>	11.4 lbs
<b>Size:</b>	22.50" x 6.63" x 2.50"
<b>Warranty:</b>	5 year limited warranty (excluding blades)

### Accessories:

PT10024162:	Carrying Case
PT10037388:	Moving Blade
PT10037384:	Fixed Blade



PT10024162 Hard Polymer Case for YCUT129ACSR

# RHCC4CUAL

## Latch Head, Remote Operated Cutter Cuts up to 4.00" Copper / Aluminum Cable

- Interference free closure for mid-span cuts
- Precision cutting blades for clean cuts
- Lightweight ergonomic design
- Durable canvas carrying bag stores tool and accessories

### For Use On:

Copper/Aluminum Cable: up to 4.00"



### Specifications:

Operating Pressure:	10,000 PSI
Weight:	19.1 lbs
Size:	21.00" x 9.25" x 5.50"
Warranty:	5 year limited warranty (excluding blades)



*BAGCNV5X9X24 Canvas Bag available separately;  
included with RHCC4CUAL cutter tool*

### Accessories:

BAGCNV5X9X24:	Canvas Bag
RHCC4CUALBLD:	Cutting Blade (one blade)
RHCC4CUALGDEBLD:	Blade Guide

*See Hydraulic Pumps and Hydraulic Hoses; Pump Accessories  
for other necessary equipment.*



## RHCC10 Series

### C-Head Remote Operated Cutter

Interchangeable cutting blades for different applications

- Easy and efficient cable cutting in both field and OEM applications
- Interchangeable precision cutting blades to cut different materials
- High strength steel cylinder
- C-head with large opening

#### For Use On:

**Copper/Aluminum Cable:** up to 1.5"

**ACSR/ACSS:** up to 1590 kcmil

**Ground Rod:** up to 5/8"

**Rebar:** up to 1/2"

**Soft Steel Bolts:** up to 5/8"

**Standard/EHS Guy:** up to 9/16"

#### Variations:

<b>RHCC10</b>	Tool with all blades
<b>RHCC10C</b>	Covered RHCC10 tool; all blades
<b>RHCC10-ACSR</b>	RHCC10 tool; only ACSR blades
<b>RHCC10-CUAL</b>	RHCC10 tool; only CUAL blades
<b>RHCC10-SOL</b>	RHCC10 tool; only SOL blades
<b>RHCC10-GUY</b>	RHCC10 tool; only GUY blades
<b>RHCC10C-ACSR</b>	Covered RHCC10 tool; only ACSR blades
<b>RHCC10C-CUAL</b>	Covered RHCC10 tool; only CUAL blades
<b>RHCC10C-SOL</b>	Covered RHCC10 tool; only SOL blades
<b>RHCC10C-GUY</b>	Covered RHCC10 tool; only GUY blades



#### Specifications:

<b>Operating Pressure:</b>	10,000 PSI
<b>Weight:</b>	13.2 lbs
<b>Size:</b>	17.58" x 4.75" x 3.00"
<b>Warranty:</b>	5 year limited warranty (excluding blades)

#### Accessories:

<b>MINBAG:</b>	Canvas Bag
<b>PT10128:</b>	Hot Stick Adapter

Replacement Blades below include screws and wrench for easy installation.

<b>HCCUAL:</b>	Copper/Aluminum Blades
<b>HCCACSR:</b>	ACSR/ACSS Blades
<b>HCCGUY:</b>	Standard/EHS Guy Blades
<b>HCCSOL:</b>	Rebar/Ground Rod/Soft Steel Bolt Blades

See Hydraulic Pumps and Hydraulic Hoses; Pump Accessories for other necessary equipment.



**HCCUAL Blades**

# Tooling

## Cutters — Remote Hydraulic



# RHCC129ACSR

## Latch Head, Remote Operated Cutter

Cuts up to 1.29" Copper / Aluminum Cable

- Interference free closure for mid-span cuts
- Precision cutting blades for clean cuts
- High strength steel cylinder
- Lightweight, ergonomic design
- Durable canvas carrying bag stores tool and accessories

### For Use On:

**Copper/Aluminum Cable:** up to 1.29"

**ACSR:** up to 1113 kcmil

**Ground Rod:** up to 5/8"

**Rebar:** up to 1/2"

**Soft Steel Bolts:** up to 5/8"

**Standard Guy:** up to 1/2"

**EHS Guy Strand:** up to 3/8"



### Specifications:

**Operating Pressure:** 10,000 PSI  
**Weight:** 5.8 lbs  
**Size:** 11.25" x 3.75" x 3.00"  
**Warranty:** 5 year limited warranty (excluding blades)

### Accessories:

**PT10043890:** Canvas Bag  
**PT10037388:** Moving Blade  
**PT10037384:** Fixed Blade  
**RHCCHSA:** Hot Stick Adapter

*See Hydraulic Pumps and Hydraulic Hoses; Pump Accessories for other necessary equipment.*



*PT10043890 Canvas Bag available separately; included with RHCC129ACSR cutter tool*

US: 1-800-346-4175 / International: 1-603-647-5299 / Canada: 1-800-387-6487 / [www.burndy.com](http://www.burndy.com)

**RHCC245CUAL**

**Latch Head, Remote Operated Cutter**  
Cuts up to 2.45" Copper / Aluminum Cable

- Interference free closure for mid-span cuts
- Precision cutting blades for clean cuts
- Lightweight ergonomic design
- Durable canvas carrying bag stores tool and accessories

**For Use On:**

**Copper/Aluminum Cable:** up to 2.45"



*PT10054094 Canvas Bag available separately;  
included with RHCC245CUAL cutter tool*



**Specifications:**

<b>Operating Pressure:</b>	10,000 PSI
<b>Weight:</b>	8.3 lbs
<b>Size:</b>	14.87" x 4.75" x 3.00"
<b>Warranty:</b>	5 year limited warranty (excluding blades)

**Accessories:**

<b>PT10054094:</b>	Canvas Bag
<b>PT10038657:</b>	Moving Blade
<b>PT10040663:</b>	Fixed Blade
<b>RHCCHSA:</b>	Hot Stick Adapter

**See Hydraulic Pumps and Hydraulic Hoses; Pump Accessories  
for other necessary equipment.**

## MCC Series

### Manual Cable Cutters

MCC600 cuts to 600 kcmil Cu/Al;  
MCC1000 cuts to 1000 kcmil Cu/Al

- Rugged, high quality steel cutting blades
- Fiberglass handles with soft grips
- Excellent cutting edge performance
- Minimum of cable distortion

#### For Use On:

**Copper/Aluminum Cable:** up to 600 kcmil (MCC600)  
up to 1000 kcmil (MCC1000)

#### Variations:

**MCC600** 3.5 lbs; 21" overall length; cuts copper and aluminum cable to 600 kcmil; max. insulation diameter 1.31"

**MCC1000** 9.0 lbs; 32" overall length; cuts copper and aluminum cable to 1000 kcmil; max. insulation diameter 1.90"



#### Specifications (MCC600):

**Weight:** 3.5 lbs  
**Size:** 21.00 x 5.00" x 2.00"  
**Max. Insulation Dia.:** 1.31"  
**Warranty:** 1 year limited warranty (excluding blades)

#### Accessories:

**MCC600BLADESET:** Replacement blades for MCC600  
**MCC1000BLADESET:** Replacement blades for MCC1000

**RCC - Cu/Al****RCC-Series Ratchet Cutters for Cu/Al**

Three variations covering a range of Cu/Al

- Rugged, high quality steel cutting blades
- Excellent cutting edge performance
- Minimum of cable distortion

**For Use On:**

**RCC600E:** Copper & Aluminum 600 kcmil

**RCC750HD:** Copper & Aluminum 750 kcmil

**RCC1000:** Copper & Aluminum 1000 kcmil

**Variations:**

**RCC600E** 10.5" overall length; cuts copper and aluminum cable to 600 kcmil; max. insulation diameter 1.05"; 1.3 lbs

**RCC750HD** 10.5" overall length; cuts copper and aluminum cable to 750 kcmil; max. insulation diameter 1.62"; 2.4 lbs

**RCC1000** 20" overall length; cuts copper and aluminum cable to 1000 kcmil; max. insulation diameter 2.38"; 5.0 lbs

**Specifications (RCC600E):**

<b>Weight:</b>	1.3 lbs
<b>Length:</b>	10.50" x 4.25" x 1.75"
<b>Max. Insulation Dia.:</b>	1.05"
<b>Warranty:</b>	1 year limited warranty (excluding blades)

**Accessories:**

<b>RPC701302:</b>	Fixed Replacement Blade for RCC1000
<b>RPC701402:</b>	Moveable Replacement Blade for RCC1000

**RCC - Cu/Al & ACSR**

**RCC-Series Cutters for Cu/Al and ACSR**

Three variations covering a range of Cu/Al and ACSR

- Quick release, bi-directional ratchet mechanism
- Rapid blade advance
- Easy cutting with minimal cable distortion

**For Use On:**

**RCC954ACSR1K:** Copper 1000 kcmil;  
 Aluminum 1000 kcmil;  
 ACSR 954 kcmil

**RCC556:** Copper 500 kcmil;  
 Aluminum 500 kcmil;  
 ACSR 556 kcmil

**RCC336:** Copper 350 kcmil;  
 Aluminum 500 kcmil;  
 ACSR 336 kcmil

**Variations:**

**RCC954ACSR1K** 22.75" overall length; 1.38" max. insulation diameter; 6.5 lbs

**RCC556** 20" overall length; 1.25" max. insulation diameter; 4.5 lbs

**RCC336** 10.5" overall length; .74" max. insulation diameter; 1.2 lbs



**RCC954ACSR1K**

**Specifications (RCC954ACSR1K):**

**Weight:** 6.5 lbs  
**Size:** 22.75" x 7.00" x 1.88"  
**Max. Insulation Dia.:** 1.38"  
**Warranty:** 1 year limited warranty (excluding blades)

**Accessories:**

**RPC705501:** Fixed Replacement Blade for RCC556  
**RPC705601:** Moveable Replacement Blade for RCC556  
**RPC902101:** Fixed Replacement Blade for RCC336  
**RPC902201:** Moveable Replacement Blade for RCC336

# RWRC916

## RWRC-Series Ratchet Wire Rope Cutters Cuts Mild and Stainless Steel

- Hardened steel blades
- Rapid blade advance
- Reduced handle force compared to scissor or compound action designs

### For Use On:

**RWRC916:** Mild Steel: 9/16" diameter  
Stainless Steel: 1/2" diameter

**RWRC516:** Mild Steel: 5/16" diameter  
Stainless Steel: 1/4" diameter



### Specifications (RWRC916):

**Weight:** 4.4 lbs  
**Size:** 20.00" x 9.00" x 2.00"  
**Mild Steel Dia.:** 9/16"  
**Stainless Steel Dia.:** 1/2"  
**Warranty:** 2 year limited warranty (excluding blades)

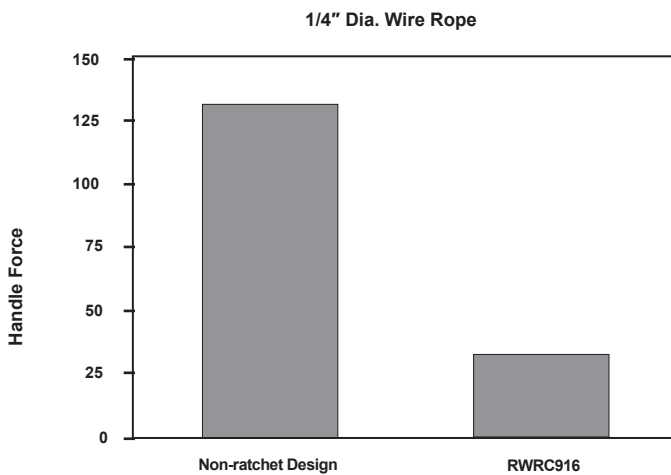

### Variations:

**RWRC916** 20" overall length; 9/16" diameter Mild Steel; 1/2" diameter Stainless Steel; 4.4 lbs

**RWRC516** 10" overall length; 5/16" diameter Mild Steel; 1/4" diameter Stainless Steel; 1.2 lbs

# Tooling Hydraulic Pumps



## Y10AC9

### Electric Hydraulic Pump; 10,000 PSI Lightweight, space saving design

- Easy to carry and transport
- Factory set relief valve
- 100,000+ life cycles
- Sealed electric pendant switch with 10-foot cord

#### For Use With:

**Y10AC9:** 10,000 PSI electric pump  
**Used with:** Y34BH, Y35BH, Y35BH4, Y39BH, Y45, Y46, Y46C, Y750BHXT, Y750CBHXT, Y644MBH, Y4PC834MBH, Y81KFTMBH, Y60BHU, Y60LW, RHCC129ACSR, RHCC245CUAL

#### Variations:

**Y10AC9OEM** Electric hydraulic pump with foot switch; pump features "Jog & Hold"

Examples of some of the remote crimping and cutting heads for use with Y10AC9 pump



Y60LW



RHCC129ACSR



RHCC10ACSR



Y4PC834MBH



#### Specifications:

<b>Weight:</b>	28.0 lbs (including oil)
<b>Motor:</b>	115V-AC 50/60 Hz 5/8 HP, 10,000 RPM
<b>Height:</b>	14.38"
<b>Base:</b>	18.00" x 8.75" x 6.50"
<b>Max. Current Draw:</b>	11 amp
<b>Reservoir Volume:</b>	1.61 quarts
<b>Warranty:</b>	5 year limited warranty

#### Accessories:

- YAC-CASE:** Steel carrying case with handle and locking latch
- YAC-FC:** Foot control switch

See Hydraulic Hoses; Pump Accessories for Hose options



## EPP10

### Electric Hydraulic Pump; 10,000 PSI

Also available in 6,000 PSI

- Lightweight, small size
- 100,000+ life cycles
- Durable remote pendent switch

#### Variations / For Use With:

**EPP10:** 10,000 PSI electric pump  
**Used with:** Y34BH, Y35BH, Y35BH-4, Y750BHXT, Y750CBHXT, Y39BH, Y45, Y46C, Y46, Y60BHU, Y60LW, RHCC Series Cutters, Y644MBH, Y4PC834MBH, Y81KFTMBH

**EPP6:** 6,000 PSI electric pump  
**Used with:** Y29BH, Y35-L

*Examples of some of the remote crimping and cutting heads for use with EPP10 pump*



#### Specifications:

<b>Motor:</b>	115V-AC/60 Hz 1/2 HP @ 3450 RPM
<b>Max. Current Draw:</b>	12.5 amperes
<b>Weight:</b>	30.0 lbs
<b>Base:</b>	18.00" x 8.00" x 6.00"
<b>Height:</b>	16.00"
<b>Reservoir Volume:</b>	2 quarts
<b>Warranty:</b>	5 year limited warranty

#### Accessories:

**EPPCASE-1:** Steel carrying case with handle, locking latch

*See Hydraulic Hoses; Pump Accessories for Hose options*

**EP10**

**Electric Hydraulic Pump; 10,000 PSI**

Also available in 6,000 PSI

- Dual voltage / hertz
- Oil level window
- 8 quart reservoir

**Variations / For Use With:**

**EP10:** 10,000 PSI electric pump; 1/2 HP 115/230 V-AC;  
60 cycle

**Used with:** Y34BH, Y35BH, Y35BH-4, Y750BHXT,  
Y750CBHXT, Y39BH, Y45, Y46C, Y46, Y60BHU,  
Y60LW, RHCC Series Cutters, Y644MBH,  
Y4PC834MBH, Y81KFTMBH

**EP10-1HP:** 10,000 PSI electric pump; 1 HP 115/230 V-AC;  
60 cycle

**Used with:** Y34BH, Y35BH, Y35BH-4, Y750BHXT,  
Y750CBHXT, Y39BH, Y45, Y46C, Y46, Y60BHU,  
Y60LW, RHCC Series Cutters

**EP10-1HP-2:** 10,000 PSI electric pump; 1/2 HP 220/230 V-AC;  
50/60 cycle

**Used with:** Y34BH, Y35BH, Y35BH-4, Y750BHXT,  
Y750CBHXT, Y39BH, Y45, Y46C, Y46, Y60BHU,  
Y60LW, RHCC Series Cutters

**EP10-2:** 10,000 PSI electric pump; 1/2 HP 220/230 V-AC;  
50/60 cycle

**Used with:** Y34BH, Y35BH, Y35BH-4, Y750BHXT,  
Y750CBHXT, Y39BH, Y45, Y46C, Y46, Y60BHU,  
Y60LW, RHCC Series Cutters

**EP6:** 6,000 PSI electric pump

**Used with:** Y35L, Y29BH



**Specifications:**

<b>Motor:</b>	1/2 HP 115/230V-AC, 60 Cycle; 1/2 HP @ 3450 RPM
<b>Max. Current Draw:</b>	10 amperes
<b>Reservoir Volume:</b>	8 quarts max; 2 quarts min.
<b>Height:</b>	17.50"
<b>Base:</b>	11.75" x 18.50"
<b>Dry Weight:</b>	68.0 lbs (86.0 lbs with max. fluid)
<b>Warranty:</b>	5 year limited warranty

**Accessories:**

*See Hydraulic Hoses; Pump Accessories for Hose options*

## EPAC10

### Electric Hydraulic Pump; 10,000 PSI

Also available in 6,000 PSI

- Roll cage
- 3 position switch and control box
- Full automatic or manual "Jog and Hold" cycles
- Windows allow easy inspection of proper oil level

#### Variations / For Use With:

**EPAC10:** 10,000 PSI electric pump  
**Used with:** Y34BH, Y35BH, Y35BH4, Y39BH, Y45, Y46, Y46C, Y750BHXT, Y750CBHXT, Y644MBH, Y4PC834MBH, Y81KFTMBH, Y60BHU, Y60LW, RHCC129ACSR, RHCC245CUAL

**EPAC6:** 6,000 PSI electric pump  
**Used with:** Y29BH, Y35-L

*Examples of some of the remote crimping and cutting heads for use with EPAC10 pump*



Y81KFTMBH



Y60LW



RHCC129ACSR



#### Specifications:

<b>Motor:</b>	1/2 HP 115/230V-AC, 60 Cycle; 1/2 HP @ 3450 RPM
<b>Max. Current Draw:</b>	10 amperes
<b>Reservoir Volume:</b>	8 quarts max; 2 quarts min.
<b>Height:</b>	17.50"
<b>Base:</b>	11.75" x 18.50"
<b>Dry Weight:</b>	68.0 lbs (82.0 lbs with max. fluid)
<b>Warranty:</b>	5 year limited warranty

#### Accessories:

*See Hydraulic Hoses; Pump Accessories for Hose options*

## HP10 and FP10

### Manual Hydraulic Pump; 10,000 PSI

Also available in 6,000 PSI

- Solid base with broad leg stabilizers
- Quick disconnect hydraulic fitting
- Built in handle for easy transport
- Factory set pressure release valve with audible click
- Quality, heavy duty foot pad with diamond plate steel (FP10)

#### Variations / For Use With:

**HP10:** 10,000 PSI hand pump  
**Used with:** Y34BH, Y35BH, Y35BH-4, Y750BHXT, Y750CBHXT, Y39BH, Y45, Y46C, Y46, Y60BHU, Y60LW, Y644MBH, Y4PC834MBH, Y81KFTMBH, RHCC Series Cutters

**HP6:** 6,000 PSI hand pump  
**Used with:** Y29BH, Y35-L

**FP10:** 10,000 PSI foot pump  
**Used with:** Y34BH, Y35BH, Y35BH-4, Y750BHXT, Y750CBHXT, Y39BH, Y45, Y46C, Y46, Y60BHU, Y60LW, RHCC Series Cutters, Y644MBH, Y4PC834MBH, Y81KFTMBH

**FP6:** 6,000 PSI foot pump  
**Used with:** Y29BH, Y35-L



*HP10 Hand Pump*

#### Specifications:

<b>Weight:</b>	18.0 lbs
<b>Size:</b>	24.75" x 6.75" x 3.00"
<b>Height (open):</b>	20.00"
<b>Reservoir Volume:</b>	1-1/8 quarts
<b>Warranty:</b>	5 year limited warranty

#### Accessories:

**BP10PADKIT:** Extended leg pad stabilizers (includes hardware)

*See Hydraulic Hoses; Pump Accessories for Hose options*

# GP10

## Gasoline Engine Driven Hydraulic Pump; 10,000 PSI

Heavy duty 4 Horse Power gasoline engine

- Sturdy steel roll cage design
- Manual control valve
- Fast hose assembly; quick disconnect hydraulic coupler
- Large 8 quart reservoir

### For Use With:

**GP10:** 10,000 PSI; 4 HP engine, 4 cycle  
**Used with:** Y34BH, Y35BH, Y35BH-4, Y750BHXT,  
Y750CBHXT, Y39BH, Y45, Y46C, Y46, Y60BHU,  
Y60BHU-D, Y60LW, RHCC Series Cutters,  
Y644MBH, Y4PC834MBH, Y81KFTMBH

*Examples of some of  
the remote crimping and  
cutting heads for use  
with GP10 pump*

Y60BHU



Y750BHXT



Y644MBH



### Specifications:

<b>Engine:</b>	4 H.P.; 4 Cycle
<b>Weight:</b>	77.8 lbs (overall dry weight)
<b>Size:</b>	21.00" x 22.25" x 16.00"
<b>Reservoir Volume:</b>	8 quarts
<b>Warranty:</b>	5 year limited warranty

### Accessories:

*See Hydraulic Hoses; Pump Accessories for Hose options*

## Hydraulic Hoses

### 10,000 PSI Non Conductive Hoses

- 3 lengths available in 2 diameters
- Orange
- Stackable couplers (male/female)

#### Variations:

PT29900-10	10' length; 3/16" diameter
PT29900-15	15' length; 3/16" diameter
PT29900-25	25' length; 3/16" diameter
PT29901-10	10' length; 1/4" diameter
PT29901-15	15' length; 1/4" diameter
PT29901-25	25' length; 1/4" diameter

#### Notes:

For proper care and maintenance of hydraulic hoses, consult the **Hydraulic Hose Care Manual; Form #7828**.

1/4" diameter (available for 10,000 PSI only) hose provides a higher flow rate for faster ram movement.



### 6,000 PSI Non Conductive Hoses

- 3 lengths available
- Orange
- Stackable couplers (male/female)

#### Variations:

PT29902-10	10' length; 3/16" diameter
PT29902-15	15' length; 3/16" diameter
PT29902-25	25' length; 3/16" diameter

# Hydraulic Hoses

## 10,000 PSI Conductive Hose

- Stackable couplers (male/female)
- Steel braided with steel spring reinforced ends
- Black

### Variations:

**PT91** 8' length; steel braided with steel spring reinforced ends; stackable couplers (male/female); Black. No electrical rating.  
**DO NOT USE ON ENERGIZED CONDUCTOR**

### Notes:

For proper care and maintenance of hydraulic hoses, consult the **Hydraulic Hose Care Manual; Form #7828**.



## 8,000 PSI Conductive Hose

- Stackable couplers (male/female)
- Steel braided with steel spring reinforced ends
- Black

### Variations:

**PT76** 8' length; steel braided with steel spring reinforced ends; stackable couplers (male/female); Black. No electrical rating.  
**DO NOT USE ON ENERGIZED CONDUCTOR**

## Accessories



### PT29074-1 Insulated Hose Carrying Bag

- Designed for protection and cleanliness for non conductive hoses; maximum carrying capacity of 10 lbs.
- Accommodates 100 feet of non-conductive hose coiled to 17-1/2" OD and 3-3/4" wide



### PT-93 (Male) and PT-94 (Female)

- Replacement couplers for 10,000 PSI operating pressure (sold separately)



### PT29091 (Male) and PT29214-1 (Female)

- Replacement couplers for 6,000 PSI operating pressure (sold separately)



### ALFLUID™ Hydraulic Fluid for Pumps

- **ALFLUIDQT** is quart size; **ALFLUIDGAL** is gallon size
- All weather hydraulic fluid for BURNDY<sup>®</sup> pumps types HP hand pump, FP foot pump, GP gasoline pump, and EPP electric pump



### PT11018 In-Line Pressure Gauge for 10,000 PSI Hydraulic Pumps

- Pressure gauge for 10,000 PSI operating hydraulic pumps



## W Die Related



### W-BG Die Set

- Double groove die set
- One (1) crimp per end on service entrance sleeves
- Requires half the number of crimps on other 5/8" sleeves



### W-28K Cutter Die Set

- Cuts #4 - 4/0 ACSR, Aluminum or Copper



### WDIETREE W Die Holder

- Innovative die holder as alternative to the standard die case
- Designed to hold up to 6 W dies
- Shown with W-BG die set (not included)



### W-687 & W-702 Non-Bowing Die Sets

- Install one-piece, full-tension UNISPLICE™ sleeves on ACSR conductors without bowing (sold separately)

**W-687:** Installs #4 ACSR 6/1, 7/1; YDS4RL and YDS4RLY  
#2 ACSR 6/1; YS2RL and YDS2RLY

**W-702:** Installs #2 ACSR 7/1; YDS021RL and YDS021RLY  
1/0 ACSR; YDS25RL and YDS25RLY



### CASEWDIES Compact Die Case

- Space for 12 W or X style dies (not included)

## MD6/MD7 Related



### MD6-CP1 Protective Jaw Covers

- Laminated vinyl jaw covers, supplied as set
- Compact, snap in place easily
- Fits all styles except Snub-Nose variations



### PT6744 Jaw Cover (Snub-Nose)

- Semi-rigid Neoprene non-conductive material
- Fits all MD6-6 Snub-nose variations



### PT4931-1 Die Button Repair Kit

- Replacement die button kit for MD6/MD7 tool variations



### PT4925 Canvas Bag

- Sturdy canvas bag for MD6/MD7 tool variations with or without covers in place
- Holds up to 9 die sets (sold separately)



### PT4952-1 Steel Carrying Case

- Provides storage for the following: MD6, MD6-6, MD6-8, MD6-14, MD6-37, MD6-38, MD7, and MD7-6 with or without covers (sold separately)
- Holds up to 18 die sets (sold separately)



### PT6733 Hotstick Tool Carrying Bag

- Heavy-duty, adjustable canvas bag
- Accommodates 48", 60" and 72" variations of the MD6 and Y35 Hotstick tools

## Accessories



### PT6545 Die Case for S or P Style Die Sets

- Metal carrying case
- Accommodates 8 S or P Style Die Sets typically used with the Y45 and Y46 series of tools



### HYFLUID™ Hydraulic Fluid for HYPRESS™ Hand Tools

- HYFLUIDQT - quart size; HYFLUIDGAL - gallon size
- Hydraulic fluid for HYPRESS™ hand tools types Y35, Y35-2, Y39, Y750HSXT, and Y750CHSXT



### PT29291 Carry Case for U Dies

- Steel case design for storage and protection of U dies
- Accommodates 15 die sets (standard or wide width U dies)
- Case is 9-1/2" x 6" x 1-1/2"
- Die sets sold separately

### Y35/Y39REPKITA Seal Repair Kit

- Seal repair kit for Y35 or Y39 tools

### Steel Carrying Cases for Y35 and Y35-2

- PT2972 - steel carrying case for Y35 tool
- PT29360 - steel carrying case for Y35-2 tool

### Adjustable Head Grip for Hot Stick PT29402-1 for Y35BH PT10128 for Y46

- Adjustable head grip for joining HYPRESS™ heads to universal hot sticks

# FORCEGAUGE12-15

## Force Test Gauge for 12 and 15 ton tools

Use with PAT46\*, PAT750, Y750 and Y35

- Custom U die blanks with detent
- Accommodates 12 ton or 15 ton tools
- Comes with custom polymer-based carry case to protect blanks and gauge

\* PUADP-1 adaptor required with PAT46 tool



*FORCEGAUGE12-15 in case  
(all items included)*

## PT29279-2 Force Test Gauge for Y39

- For Y39 HYPRESS™ tools
- Not recommended for remote powered heads
- Easy to read dial; includes operating and maintenance manual and test dies



*FORCEGAUGE12-15 with die blanks (included)*

### Gauge Specifications:

<b>Weight:</b>	2.7 lbs (4.5 lbs for entire kit)
<b>Size:</b>	8.30" x 4.30" x 1.50"
<b>Warranty:</b>	1 year limited warranty



### Gauge Specifications:

<b>Weight:</b>	2.7 lbs
<b>Size:</b>	9.25" x 3.88" x 2.00"
<b>Warranty:</b>	1 year limited warranty

# WIREMIKE

## Stainless Steel Wire Micrometer

Available in Inch or Decimal format

- Strong, durable, high quality
- Measures I.D. and O.D. of tubing
- Measures thin-wall and rigid conduit including IPS
- Measures ACSR, stranded and solid commercial cables
- Use as caliper or ruler

### For Use On:

#### ACSR

#6 to 336.4 (26/7) Stranded

#### Stranded AWG

#18 to 2000 kcmil

#### Solid

#20 to 4/0 AWG

#### IPS Tubing (Cu/Al) and Rigid Conduit:

1/4" to 2-1/2"

#### Tubing Sizes:

3-1/8" inside maximum; 2-15/16" outside maximum

#### Thin-wall Conduit:

3/8" to 2-1/2"

### Variations:

**WIREMIKE** Stainless Steel WIREMIKE™ with inch/fraction markings

**WIREMIKE-D** Stainless Steel WIREMIKE™ with decimal markings

**RK194-2** Convenience packaging of WIREMIKE (with inch markings) in packaging suitable for hanging on a rack; sold in multiples of 10 only



WIREMIKE

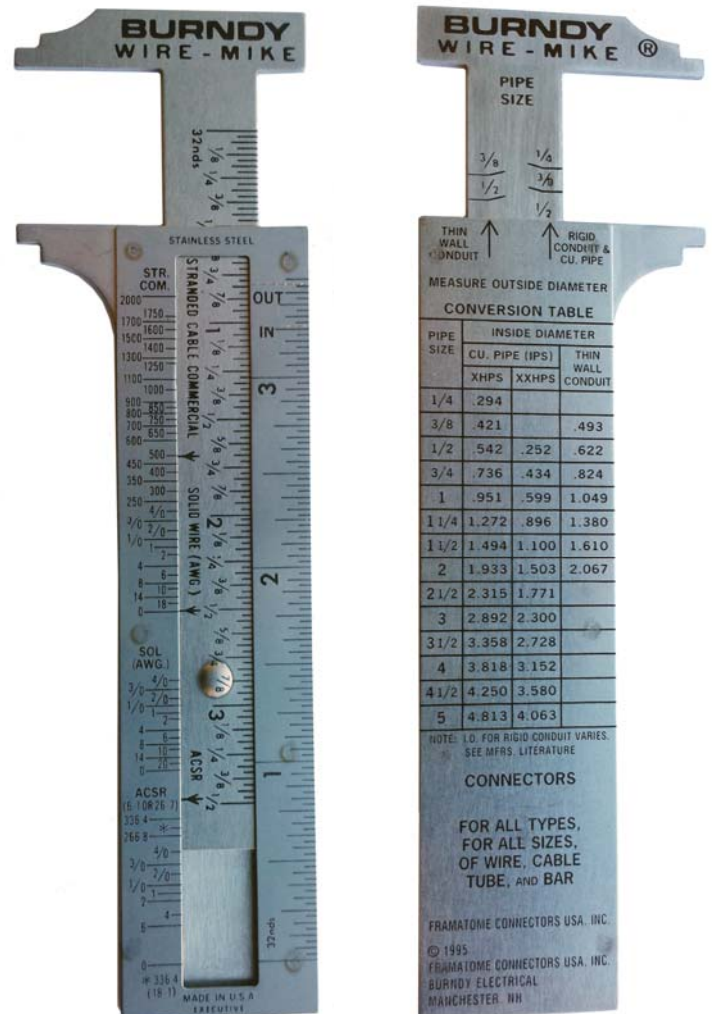

MEASURE OUTSIDE DIAMETER			
CONVERSION TABLE			
PIPE SIZE	INSIDE DIAMETER		
	CU. PIPE (IPS)	THIN WALL CONDUIT	RIGID CONDUIT & CU. PIPE
1/4	.294		
3/8	.421		.493
1/2	.542	.252	.622
3/4	.736	.434	.824
1	.951	.599	1.049
1 1/4	1.272	.896	1.380
1 1/2	1.494	1.100	1.610
2	1.933	1.503	2.067
2 1/2	2.315	1.771	
3	2.892	2.300	
3 1/2	3.358	2.728	
4	3.818	3.152	
4 1/2	4.250	3.580	
5	4.813	4.063	

NOTE: I.D. FOR RIGID CONDUIT VARIES. SEE MFRS. LITERATURE

**CONNECTORS**

FOR ALL TYPES, FOR ALL SIZES, OF WIRE, CABLE TUBE, AND BAR

FRAMATOME CONNECTORS USA, INC.  
© 1995  
FRAMATOME CONNECTORS USA, INC.  
BURNNDY ELECTRICAL  
MANCHESTER, NH

# Tooling

## Adjustable - Ratchet Torque Tools



### BTW Series

#### Micro-Adjustable Professional Grade Hand-operated "Click-Type" Torque Wrenches

- Ratcheting, calibrated, dual direction
- Positive lock with spring-loaded pull-down lock ring
- Individually serialized with matching certificate of calibration traceable to N.I.S.T.
- ASME B107.14M-1994 and ISO 6789

#### For Use On:

Any mechanical connection with torque values within range of specific torque wrench. Including, but not limited to:

Types: SERVIT<sup>®</sup>, OKLIP<sup>™</sup>VERSITAP<sup>™</sup>, SCRULUG<sup>™</sup>, Lay-In QIKLUG<sup>™</sup>, VARITAP<sup>™</sup>, VARILUG<sup>™</sup>, KA-U Universal Terminals, UNITAP<sup>™</sup>, POLYTAP<sup>™</sup>, BARTAP<sup>™</sup>, Type BIPC, Terminal Blocks, U-BLOK<sup>™</sup>, SPEC-BLOK<sup>™</sup>, VERSIPOLE<sup>™</sup>

#### Variations:

**BTW30150** Torque range 30 - 150 in-lbs; 10.25" long; 3/8" drive

**BTW150750** Torque range 150 - 750 in-lbs; 16.00" long; 3/8" drive

**BTW1575F12** Torque range 15 - 75 ft-lbs; 16.00" long; 1/2" drive



#### Specifications:

**Accuracy:** ±4% clockwise; ±6% counter clockwise of indicated value clockwise, from 20% to 100% of full scale

**Applicable Standards:** ASME B107.14M-1994; ISO 6789

**Calibration:** Traceable to N.I.S.T.

**Warranty:** 1 year limited warranty



Design Selection

**Auger Bits for Wood, Fiberglass, Composite Poles**

	<b>DOMINATOR</b>	<b>RAZOR</b>	<b>ELIMINATOR™</b>	<b>HOLLOW CORE</b>	<b>SOLID CORE</b>
<b>Material Drilled</b>	Treated Wood	Treated Wood	Treated Wood	Fibreglass Composite	Fibreglass Composite
<b>TIP</b>	Hardened Steel	Hardened Steel	Carbide Tip	Carbide Tip	Carbide Tip
<b>Features and Benefits</b>	Single flute Aggressive lead screw Very fast drilling Cuts hardest of woods Self-feeding	Single flute Aggressive lead screw Added "spur" Fast drilling Extra clean holes No re-drilling required Self-feeding	Carbide tip Single flute Patented cutting geometry Fast drilling Very clean holes Easy fastener insertion Lowest cost/hole drilled Can be refurbished	Specialized short flute "Solid" body design Carbide Tip Engineered cutting tip Designed for fiberglass Cuts quickly and cleanly No splinters No melting Drill both holes at once Can be re-sharpened	Specialized long flute "Fluted" body design Carbide Tip Engineered cutting tip Designed for fiberglass Cuts quickly and cleanly No splinters No melting Removes debris quickly Drill both holes at once Can be re-sharpened
<b>HOLES*</b>	100+	100+	2000+	500+	500+

\*Approximate comparison of # holes drilled/bit



*HIW716MAG Hydraulic Impact Wrench*

# Part Number Chart

## Auger Bits for Wood, Fiberglass, Composite Poles

OAL	DIA	TREATED WOOD			FIBERGLASS / COMPOSITE	
		DOMINATOR	RAZOR	ELIMINATOR™	HOLLOW CORE	SOLID CORE
8"	9/16"		LPHTBIT9168R			
12"	9/16"				LPHTBIT91612HC	
12"	11/16"				LPHTBIT111612HC	LPHTBIT111612SC
12"	13/16"				LPHTBIT131612HC	LPHTBIT131612SC
12"	1 1/8"				LPHTBIT11812HC	
18"	11/16"				LPHTBIT111618HC	
18"	13/16"				LPHTBIT131618HC	LPHTBIT131618SC
18"	1/2"			LPHTBIT1218		
18"	9/16"		LPHTBIT91618R			
18"	5/8"	LPHTBIT5818D	LPHTBIT5818R			
18"	11/16"	LPHTBIT111618D	LPHTBIT111618R	LPHTBIT111618		
18"	3/4"	LPHTBIT3418D	LPHTBIT3418R			
18"	13/16"	LPHTBIT131618D	LPHTBIT131618R	LPHTBIT131618		
18"	7/8"	LPHTBIT7818D				
18"	15/16"	LPHTBIT151618D	LPHTBIT151618R	LPHTBIT151618		
24"	5/8"	LPHTBIT5824D				
24"	11/16"	LPHTBIT111624D	LPHTBIT111624R			
24"	3/4"	LPHTBIT3424D				
24"	13/16"	LPHTBIT131624D	LPHTBIT131624R	LPHTBIT131624		
24"	15/16"	LPHTBIT151624D	LPHTBIT151624R			
24"	1 1/8"	LPHTBIT11824D	LPHTBIT11824R			

Other styles and sizes are available on request



*HIW716ENF Hydraulic Impact Wrench*



# HIW716ENF

## ENFORCER® Hydraulic Impact Wrench

Variable Torque; 7/16" Quick Chuck

- Industry exclusive torque selector allows switching between 200 and 515 ft-lb torque settings
- Dual spool selector for Open and Closed systems
- Cartridge style valves for greater accuracy
- Internal safety relief valve

### Variations:

**HIW716ENFTG** HIW716ENF wrench provided with factory installed HIW716ENFTGKIT



**HIW716ENF ENFORCER®** Hydraulic Impact Wrench  
*shown with trigger guard, adaptors and couplers*

*See our complete line of Auger Bits*



### Specifications:

<b>Chuck Type:</b>	7/16" Quick Change
<b>Opt. Pressure:</b>	750-2000 PSI
<b>Flow Range:</b>	4-12 GPM
<b>Opt. Flow Range:</b>	4-8 GPM
<b>Weight:</b>	6.0 lbs
<b>Torque:</b>	515 ft-lbs
<b>Size:</b>	9.00" x 7.75" x 3.12"
<b>Warranty:</b>	5 year limited warranty

### Accessories:

<b>HIW716ENFTGKIT:</b>	Trigger guard assembly kit
<b>LPHTADPMMOP66:</b>	Male to male adaptor for use with couplers listed below *(Qty. 2)
<b>LPHTHTMANOSE66:</b>	Male coupling 3/8" NPT *(Qty. 1) per tool Qty. 2 per hose
<b>LPHTHTMABODY66:</b>	Female coupling 3/8" NPT *(Qty. 1) per tool Qty. 2 per hose
<b>LPHTHOSNCR66668:</b>	3/8" X 8' hose set *(Qty. 1)

\*(Recommended quantity for use with HIW716ENF)

*See Low Pressure Hydraulic Accessories for additional options*

# HIW716MAG

## MAG Series, Hydraulic Impact Wrench Machined Aluminum, Gerotor Design

- Aircraft grade extruded aluminum body, forged handle
- CNC machined parts
- Frictionless gerotor motor
- Cartridge style valve
- 7/16" Tri-ball quick change chuck
- Dual spool selector for Open & Closed systems
- "Glove-sized" wide grip activation trigger
- Inlet/Outlet SAE 6 adapters
- Reverse flow and hook-up protection
- Injection molded thermally insulated textured comfort grips
- Forward/Reverse selector

### Variations:

HIW716MAGKIT1	Wrench, flat face couplers
HIW716MAGKIT2	Wrench, swivels, 8' NCR hose, flat face couplers
HIW716MAGKIT3	Wrench, swivels, 10' NCR hose, flat face couplers
HIW716MAGKIT4	Wrench, flat face couplers, trigger guard
HIW716MAGKIT5	Wrench, flat face couplers, trigger guard, handle



### Specifications:

Chuck Type:	7/16" Tri-ball quick chuck
Opt. Pressure:	1,000 - 2,250 PSI
Flow Range:	4 - 12 GPM
Opt. Flow Range:	4 - 8 GPM
Weight:	7.6 lbs
Torque:	550 ft-lbs
Size:	9.62" x 9.00" x 3.62"
Warranty:	5 year limited warranty

### Accessories:

#### LPHTADPMM71612

7/16" quick chuck to 1/2" square drive adapter

#### LPHTADPMMOP66 (2 required)

SAE #6 to 3/8" NPT male-to-male adaptor

#### LPHTHTMANOSE66

3/8" male coupler (flat face) with 3/8" NPT (female thread)

#### LPHTHTMABODY66

3/8" female coupler (flat face) with 3/8" NPT (female thread)

#### LPHTHOSNCR66668

8', 3/8" NPT, 3/8" NPT Non-conductive hose

#### LPHTADPSMFOP66 (2 required)

SAE swivel adaptor

*See Low Pressure Hydraulic Accessories for additional options*



**MAGHOLSTER**  
(tool not included)

Also see our full line of Auger Bits!

# LPHY750XT

## KOMPRESSOR™ Remote Operated 12 Ton Low Pressure Hydraulic Compression Tool

- Visual and audible crimp indicator
- 1.65" jaw opening covers a range of applications
- 350° head rotation
- Uses all standard BURNDY® U dies
- Crimp time approximately 2 seconds

### For Use On:

#### Tension Sleeves

Copper	#8 sol. - 500 kcmil
Aluminum	#8 sol. - 587.2 kcmil
ACSR	#4 - 556.5 kcmil

#### Taps

Copper	#14 sol. - 500 kcmil
Aluminum	#8 - 500 kcmil

#### Aerial Cable

Copper	#6 - 500 kcmil
--------	----------------

#### Terminals & Splices

Copper	#8 - 750 kcmil
Aluminum	#8 - 750 kcmil
ACSR	#4 - 556.5 kcmil

#### HYGROUND® (Compression Grounding)

Copper	#8 - 500 kcmil
Ground Rods	1/2" - 1" diameter

### Variations:

LPHY750CXT LPHY750XT with molded rubber covering



### Specifications:

Flow Rate:	3 - 9 GPM (11 - 34 LPM)
Operating Pressure:	1,500 - 2,500 PSI (103 - 172 BAR)
Force Developed:	12 Tons
Die Style:	U dies
Jaw Opening:	1.65"
Weight:	21.0 lbs (9.5 kg)
Size:	20.75" x 15.00" x 12.00"
Max. Back Pressure:	250 PSI (17 BAR)
Warranty:	5 year limited warranty

### Accessories:

LPHTHOSNCR66668OP:	Direct connect 8' non-conductive hose set
LPHTHOSNCR666610OP:	Direct connect 10' non-conductive hose set
LPHTHOSNCR66668:	*8' non-conductive hose set
LPHTHOSNCR666610:	*10' non-conductive hose set
LPHTHTMANOSE66:	Male coupler 3/8" HTMA
LPHTHTMABODY66:	Female coupler 3/8" HTMA
LPHTADPSMFOP66:	Swivel Adapter

\*These hoses are used with LPHTADPSMFOP66 swivel adapter

See Low Pressure Hydraulic Accessories for additional options

## HBR Series

### Hydraulic Breakers

Light/Medium Duty (HBR40)  
Medium/Heavy Duty (HBR66)

- Control trigger built into handle
- Provided with 18" braided whip hoses (couplers ordered separately)
- Standard tool attachment mechanism allows use of all standard tool bits

#### Variations:

**HBR40** Light to Medium Duty Hydraulic Breaker  
Performance: 45-55 lb class breakers;  
Weight: 40 - 48 lbs.; Length: 25";  
Tool Steel Capacity: 1" x 4-1/4"

**HBR66** Medium to Heavy Duty Hydraulic Breaker  
Performance: 60 - 80 lb class breakers;  
Weight: 50 - 67 lbs.; Length: 27" to 35";  
Tool Steel Capacity: 1-1/4" x 6"



*HBR66 Medium and Heavy Duty Hydraulic Breaker*



*HBR40 Light and Medium Duty Hydraulic Breaker*

#### Specifications:

Flow:	4 - 7 GPM (15 - 27 LPM)
Optimum Flow:	4 GPM (15 LPM)
Pressure:	1200- 2000 PSI (85 - 140 BAR)
Max. Back Pressure:	150 PSI (11 BAR)
Whip Hoses:	18" with 3/8" NPT fittings
Warranty:	5 year limited warranty

#### Accessories:

*See Low Pressure Hydraulic Accessories for options*

## Submersible Pumps

**Fully Submersible, 1,000-2,000 PSI Pumps**  
Provided with whip hoses

- Self-lubricating design
- Totally submersible
- Can run dry without damage
- Open/Closed Center operation

### Variations:

**HP3** 3" Submersible pump; 7-10 GPM flow; 36 lbs.; Pump capacity: 750 GPM (2800 LPM); Gear Motor; 3" Male Cam-lock; 50' maximum lift

**HTP3** 3" Submersible pump; 7-10 GPM flow; 40 lbs.; Pump capacity: 500 GPM (1900 LPM); Gear Motor; 3" Male Cam-lock; 40' maximum lift; 1/2" x 14 (#8) NPT (F)

**HP2HV** Submersible pump adaptable to 2" or 2-1/2" discharge; 4-9 GPM flow; 13 lbs.; Pump capacity: 340 GPM; Gerotor Motor



**HP3**

### Accessories:

**HOSE325:** 25 ft. long hose (for HP3, HTP3)

**HOSE350:** 50 ft. long hose (for HP3, HTP3)

**HP2CAMLOCKHOSESET:** Hose Set Kit (for HP2HV)

**HOSE2:** 25 ft. long hose (for HP2HV)

*See Low Pressure Hydraulic Accessories for additional options*



**HTP3**



**HP2HV**

# HPT-R1 Series

## Low Pressure Hydraulic Pole Tampers

Available with or without On/Off Valve

- Patented valving prevents impacting of ram within tamper
- Stroke amplitude of 1-5/8"
- Stroke frequency of 1375 blows/min
- Interchangeable heavy duty tamper shoes (sold separately)

### Variations:

<b>HPT60R1</b>	60" length; 29 lbs; with On/Off valve
<b>HPT72R1</b>	72" length; 30 lbs; with On/Off valve
<b>HPT84R1</b>	84" length; 32 lbs; with On/Off valve
<b>HPT96R1</b>	96" length; 34 lbs; with On/Off valve
<b>HPT59R1</b>	59" length; 26 lbs; without On/Off valve
<b>HPT71R1</b>	71" length; 28 lbs; without On/Off valve
<b>HPT83R1</b>	83" length; 31 lbs; without On/Off valve



*Hydraulic Breaker with On/Off Valve*



*Hydraulic Breaker  
without On/Off Valve*

**TS-KD**  
*Kidney Tamper Shoe*

**TS-SQ**  
*Square Tamper Shoe*

### Specifications:

<b>Flow:</b>	4-10 GPM (15-38 LPM)
<b>Pressure:</b>	1000-2000 PSI (70-140 BAR)
<b>Max. Back Pressure:</b>	250 PSI (17 BAR)
<b>Operation:</b>	Open/Closed Center
<b>Stroke Amplitude:</b>	1-5/8"
<b>Stroke Frequency:</b>	1375 per minute
<b>Tool Ports:</b>	#6 SAE O-Ring (F)
<b>Warranty:</b>	5 year limited warranty

### Accessories:

<b>TK-KD:</b>	Kidney shoe; 3" x 8" (7.6 cm x 20.3 cm)
<b>TK-SQ:</b>	Square shoe; 8" x 8" (20.3 cm x 20.3 cm)
<b>LPWHPKITD:</b>	Whip Hose Kit

*See Low Pressure Hydraulic Accessories for additional options*

## HHS Series

### Hydraulic Hand Chain and Pole Saws

#### Low Pressure Hydraulic Chain Saws

- Gerotor-type motor has lifetime warranty
- .325" pitch anti-kickback chain
- Dual action spool switches from open to closed center operation easily

#### Variations:

##### Hydraulic Hand Chain Saws:

- HHS-O/C-B13** 13" cutting capacity; 15-1/2" bar length; 7.5 lbs; 24" overall length
- HHS-O/C-B16** 16" cutting capacity; 18-1/2" bar length; 8.0 lbs; 27" overall length
- HHS-O/C-B20** 20" cutting capacity; 22-1/2" bar length; 8.5 lbs; 30" overall length

##### Hydraulic Pole Chain Saws:

- HHS-O/C-4-B13** 76" (6'4") overall length; 4' pole length; 15-1/2" bar length; 13" cutting capacity; 9.0 lbs
- HHS-O/C-5-B13** 88" (7'4") overall length; 5' pole length; 15-1/2" bar length; 13" cutting capacity; 9.5 lbs

#### Accessories:

See *Low Pressure Hydraulic Accessories* for options



**HHS-O/C-B13**

Low Pressure Hydraulic Hand Chain Saw

#### Specifications:

<b>Flow:</b>	5-8 GPM (19-30 LPM)
<b>Pressure:</b>	1000-2000 PSI (70-140 BAR)
<b>Max. Back Pressure:</b>	250 PSI (17 BAR)
<b>Operation:</b>	Open/Closed Center
<b>Motor:</b>	Gerotor (lifetime warranty)
<b>Chain:</b>	.325" pitch anti-kickback
<b>Tool Ports:</b>	#6 SAE O-Ring (F)
<b>Warranty:</b>	5 year limited warranty



**HHS-O/C-4-B13**

Low Pressure Hydraulic Pole Chain Saw

## HPS-LW Series

### Hydraulic Pole Saws

Lightweight, low pressure hydraulic

- CNC machined Aircraft grade solid Aluminum body and handle
- Branch hook
- Cartridge style valve
- External bar oiler
- 2-stage safety trigger, anti-kickback chain and anti-slip grip
- Fiberglass tube tested at final assembly with AB Chance Hot Stick Tester Model CC403-3178 to the value specified as per OSHA 1910.269

#### Variations:

**HPS1371LW** 71" overall length; 1.312" pole diameter; 13" cutting capacity; 8.0 lbs

**HPS1383LW** 83" overall length; 1.312" pole diameter; 13" cutting capacity; 8.2 lbs

#### Specifications:

<b>Flow:</b>	4-8 GPM (16-30 LPM)
<b>Pressure:</b>	1000-2000 PSI (70-140 BAR)
<b>Max. Back Pressure:</b>	250 PSI (17 BAR)
<b>Operation:</b>	Open/Closed Center
<b>Motor:</b>	Gear
<b>Chain:</b>	.325" pitch anti-kickback
<b>Tool Ports:</b>	#6 SAE O-Ring
<b>Warranty:</b>	5 year limited warranty

#### Accessories:

See *Low Pressure Hydraulic Accessories* for additional options





## HPP Series

### Hydraulic Power Pack, Low Pressure

Available for single or dual circuit

- Integral oil cooling system
- Fully shrouded fan and changeable oil filter
- Manual choke with adjustable throttle mechanism

#### Variations:

**HPP18** Output/Flow 1 @ 2000 PSI @ 1-10 GPM (138 Bar @ 0-38 LPM); 18 HP @ 3500 RPM; Variable GPM output valve

**HPP18-2** Output/Flow 2 @ 2000 PSI @ 5 GPM or 1 @ 2000 PSI @ 10 GPM; can simultaneously operate two (2) 5 GPM tools OR 1 (1) tool at 10 GPM; 18 HP @ 3500 RPM

**HPP5** Output/Flow 1 @ 1450 PSI; L: 20" x H: 18" x W: 17"  
5.5 HP engine with recoil start; Dry Weight: 83 lbs;  
Fuel Tank Capacity: 1 gallon; Hydraulic Oil Capacity:  
1.25 gallons

*Examples of some of the tools  
for use with the HPP series of  
Hydraulic Power Packs.*



#### Specifications (HPP18 Series):

<b>Dry Weight:</b>	233 lbs (105.6 kg)
<b>Size:</b>	35.00" x 32.00" x 29.00"
<b>Motor:</b>	18 HP @ 3500 RPM
<b>Warranty:</b>	5 year limited warranty

#### Accessories:

*See Low Pressure Hydraulic Accessories for options*

# LPHT Accessories

Catalog Number	Description
LPHT3CHISEL11418	3" Chisel, 1-1/4", hex, 18" long
LPHTASPHALTCUT118	Asphalt cutter, 1-1/8" hex
LPHTCLAYSPADE118	Clay spade, 1-1/8" hex
LPHTGRDVR11458	Ground rod driver, 1-1/4" hex, 5/8" rod
LPHTMOILPT118	Moil point, 1" hex, 18" long
LPHTNARCHISEL11814	Narrow chisel, 1-1/8" hex, 14" long
LPHTADPMM71612	7/16" Quick chuck adaptor x 1/2" square
HIW71612TGKIT	Trigger guard for HIW716
LPHTADPMMOP66	ADP Male/Male SAE #6, 3/8 NPT (2 required per tool)
<b>LPHT HOSES Red or Orange</b>	
LPHTHOSNCR666610	Hose; Insulated, 10 foot; 3/8 NPT, 3/8 NPT
LPHTHOSNCR66668	Hose; Insulated, 8 foot; 3/8 NPT, 3/8 NPT
LPHTHOSNCR6668OP	Hose; Insulated, 8 foot, SAE #6, 3/8 NPT
LPHTHOSNCR666610OP	Hose; Insulated, 10 foot, SAE #6, 3/8 NPT
<b>COUPLERS</b>	
LPHTDRIPBODY66	Dripless body; 3/8 body, 3/8 NPT
LPHTDRIPBODY88	Dripless body; 1/2 body; 1/2 NPT
LPHTDRIPNOSE66	Dripless nose; 3/8 nose, 3/8 NPT
LPHTDRIPNOSE88	Dripless nose; 1/2 nose, 1/2 NPT
LPC38S	3/8, 3/8 NPT Flush face coupler set (body & nose)
LPC12S	3/8, 1/2 NPT Flush face coupler set (body & nose)
LPHTHTMADUSTCAPF	HTMA dust cap body
LPHTHTMADUSTCAPM	HTMA dust cap nose
<b>SOCKETS</b>	
LPHTSOC121	Socket - 1/2" drive x 1"
LPHTSOC121116	Socket - 1/2" drive x 11/16"
LPHTSOC12112	Socket - 1/2" drive x 1-1/2"
LPHTSOC12114	Socket - 1/2" drive x 1-1/4"
LPHTSOC12118	Socket - 1/2" drive x 1-1/8"
LPHTSOC1212	Socket - 1/2" drive x 1/2"
LPHTSOC121316	Socket - 1/2" drive x 13/16"
LPHTSOC12138	Socket - 1/2" drive x 1-3/8"
LPHTSOC121716	Socket - 1/2" drive x 1-1/16"
LPHTSOC1234	Socket - 1/2" drive x 3/4"
LPHTSOC1258	Socket - 1/2" drive x 5/8"
LPHTSOC1278	Socket - 1/2" drive x 7/8"
LPHTSOC12916	Socket - 1/2" drive x 9/16"
HIW12SOCSET	Socket set - 1/2" drive DP IMP 6 Point

**NOTE:**

*Only the most common accessories and sizes are shown. BURNDY has over 200 accessory items for your Low Pressure Hydraulic needs; if you don't see what you are looking for call us at Customer Service: 1-800-346-4175.*

*Auger Bits are featured on the Auger Bit pages earlier in the catalog.*



# Knockout Sets

## Mechanical and Ratchet Knockout Sets

- Four-point design allows slug to drop automatically without splitting
- Punches up to 10-gauge mild steel
- Kits include most popular sizes of punches and dies, see Variations; all items may be purchased separately
- 1-year limited warranty

### Variations:

- BKOM50125** Kit for 1/2" to 1-1/4" Conduit Size; includes punches and dies for 1/2", 3/4", 1", 1-1/4", 1/2" bearing and drive screw, 3/4" to 2" bearing and drive screw; sturdy plastic storage case
- BKOM152** Kit for 1-1/2" to 2" Conduit Size; includes punches and dies for 1-1/2" and 2", 3/4" to 2" bearing and drive screw; sturdy plastic storage case
- BKOH2540** Expansion Kit for 2-1/2" to 4" Conduit Size; includes punches and dies for 2-1/2", 3", 3-1/2", 4". Generally used with the 1/2" to 2" sets, no bearing or drive screws are included; metal storage case
- BKOW520** Ratchet Wrench Kit for 1/2" to 2" Conduit Size; includes punches and dies for 1/2", 3/4", 1", 1-1/4", 2", 1/2" bearing and drive screw, 3/4" to 2" bearing and drive screw; Hand Ratchet Wrench; sturdy plastic storage case
- BKOR520** Quick Hand Ratchet Wrench Kit for 1/2" to 2" Conduit Size; 10-gauge mild steel or 12-gauge stainless steel; includes punches and dies for 1/2", 3/4", 1", 1-1/4", 1-1/2", 2", Ratchet, 1/2" screw adapter, 1-1/2" to 2" screw adapter; metal storage case

### Accessories:

- BKP500B:** 1/2" Punch; 7/8" Hole; included in BKOM50125, BKOW520, and BKOR520
- BKD500B:** 1/2" Die; 7/8" Hole; included in BKOM50125, BKOW520, and BKOR520
- BKP750B:** 3/4" Punch; 1-3/32" Hole; included in BKOM50125, BKOW520, and BKOR520
- BKD750B:** 3/4" Die; 1-3/32" Hole; included in BKOM50125, BKOW520, and BKOR520



**BKOM50125**

### Accessories: (Continued)

- BKP1000B:** 1" Punch; 1-11/32" Hole; included in BKOM50125, BKOW520, and BKOR520
- BKD1000B:** 1" Die; 1-11/32" Hole; included in BKOM50125, BKOW520, and BKOR520
- BKP1250B:** 1-1/4" Punch; 1-11/16" Hole; included in BKOM50125, BKOW520, and BKOR520
- BKD1250B:** 1-1/4" Die; 1-11/16" Hole; included in BKOM50125, BKOW520, and BKOR520
- BKSB50B:** 1/2" Bearing & Drive Screw; included in BKOM50125 and BKOW520
- BKS752B:** 3/4" to 2" Bearing & Drive Screw; included in BKOM50125, BKOM152, and BKOW520
- BK88004:** Sturdy plastic case; included with BKOM50125
- BKP1500B:** 1-1/2" Punch; 1-15/16" Hole; included in BKOM50125, BKOW520, and BKOR520
- BKD1500B:** 1-1/2" Die; 1-15/16" Hole; included in BKOM50125, BKOW520, and BKOR520
- BKP2000B:** 2" Punch; 2-3/8" Hole; included in BKOM152, BKOW520, and BKOR520
- BKD2000B:** 2" Die; 2-3/8" Hole; included in BKOM152, BKOW520, and BKOR520
- BK88001:** Sturdy plastic case; included with BKOM152
- BKP2500:** 2-1/2" Punch; 2-7/8" Hole; included in BKOH2540
- BKD2500:** 2-1/2" Die; 2-7/8" Hole; included in BKOH2540
- BKP3000:** 3" Punch; 3-1/2" Hole; included in BKOH2540
- BKD3000:** 3" Die; 3-1/2" Hole; included in BKOH2540
- BKP3500:** 3-1/2" Punch; 4" Hole; included in BKOH2540
- BKD3500:** 3-1/2" Die; 4" Hole; included in BKOH2540
- BKP4000:** 4" Punch; 4-1/2" Hole; included in BKOH2540
- BKD4000:** 4" Die; 4-1/2" Hole; included in BKOH2540
- BK88008:** Sturdy metal case; included with BKOH2540
- BKW52:** Hand Ratchet Wrench; included in BKOW520
- BK88007:** Sturdy plastic case; included with BKOW520
- BKOR14:** Ratchet; included in BKOR520
- BKOR50:** 1/2" Screw Adapter; included in BKOR520
- BKOR75125:** 3/4" to 1-1/4" Screw Adapter; included in BKOR520
- BKOR152:** 1-1/2" to 2" Screw Adapter; included in BKOR520
- BK88020:** Metal storage case; included in BKOR520

# Knockout Sets

## Self-Contained Hydraulic

For 1/2" to 2" Conduit

- Punches up to 2" conduit sizes, up to 10-gauge mild steel or 12-gauge stainless steel
- Four-point design allows slug to drop automatically without splitting
- Kits include most popular sizes of punches and dies, see Variations; all items may be purchased separately
- 1 year limited warranty

### Variations:

**BKOS5290** Right-angle head swivels 360°; Kit for 1/2" to 2" Conduit Size; includes punches and dies for 1/2", 3/4", 1", 1-1/4", 1-1/2" and 2"; Hydraulic Driver, 2 Drawstuds and a Drawstud Adapter; sturdy metal case

**BKOS520** Kit for 1/2" to 2" Conduit Size; includes punches and dies for 1/2", 3/4", 1", 1-1/4", 1-1/2", and 2"; Hydraulic Driver, 2 Drawstuds and a Drawstud Adapter; sturdy metal case

### Accessories:

- BKP500B:** 1/2" Punch; 7/8" Hole; included in BKOS5290, and BKOS520
- BKD500B:** 1/2" Die; 7/8" Hole; included in BKOS5290 and BKOS520
- BKP750B:** 3/4" Punch; 1-3/32" Hole; included in BKOS5290 and BKOS520
- BKD750B:** 3/4" Die; 1-3/32" Hole; included in BKOS5290 and BKOS520
- BKP1000B:** 1" Punch; 1-11/32" Hole; included in BKOS5290 and BKOS520
- BKD1000B:** 1" Die; 1-11/32" Hole; included in BKOS5290 and BKOS520
- BKP1250B:** 1-1/4" Punch; 1-11/16" Hole; included in BKOS5290 and BKOS520
- BKD1250B:** 1-1/4" Die; 1-11/16" Hole; included in BKOS5290 and BKOS520
- BKP1500B:** 1-1/2" Punch; 1-15/16" Hole; included in BKOS5290 and BKOS520
- BKD1500B:** 1-1/2" Die; 1-15/16" Hole; included in BKOS5290 and BKOS520
- BKP2000B:** 2" Punch; 2-3/8" Hole; included in BKOS5290 and BKOS520



**BKOS5290**



**BKOS520**

### Accessories: (Continued)

- BKD2000B:** 2" Die; 2-3/8" Hole; included in BKOS5290 and BKOS520
- BKLP6:** Hydraulic Driver; included in BKOS5290
- BKPR7520:** Drawstud; included in BKOS5290 and BKOS520
- BKPS50:** Drawstud; included in BKOS5290 and BKOS520
- BKSA50:** Drawstud Adapter; included in BKOS5290 and BKOS520
- BKLP6K1:** Seal Repair Kit for BKOS5290
- BKLP2:** Hydraulic Driver; included in BKOS520
- BK88020:** Metal Storage Case; included in BKOS520
- BKLP2K1:** Seal Repair Kit for BKOS520

## Knockout Sets

### Hydraulic Knockout Sets with Pump

- Punches up to 10-gauge mild steel or 12-gauge stainless steel
- Kits include most popular sizes of punches and dies, see Variations; all items may be purchased separately
- 1 year limited warranty

#### Variations:

- BKOH520A** Kit for 1/2" to 2" Conduit Size; includes punches and dies for 1/2", 3/4", 1", 1-1/4", 1-1/2", and 2"; 2 speed hand pump, Drawstud for 3/4" to 4" punches/dies; 3/8" Stainless Steel Drawstud\*, Converter\*\*, 12-ton hydraulic cylinder, 6' rubber hose with couplers and heavy duty metal storage case
- BKOH540A** Kit for 1/2" to 4" Conduit Size; includes punches and dies for 1/2", 3/4", 1", 1-1/4", 1-1/2", 2", 2-1/2", 3", 3-1/2", and 4"; 2 speed hand pump, Drawstud for 3/4" to 4" punches/dies; 3/8" Stainless Steel Drawstud\*, Converter\*\*, 12-ton hydraulic cylinder, 6' rubber hose with couplers and heavy duty metal storage case
- BKOF540** Kit for 1/2" to 4" Conduit Size; includes punches and dies for 1/2", 3/4", 1", 1-1/4", 1-1/2", 2", 2-1/2", 3", 3-1/2", and 4"; 2 speed foot pump, Drawstud for 3/4" to 4" punches/dies; 3/8" Stainless Steel Drawstud\*, Converter\*\*, 12-ton hydraulic cylinder, 6' rubber hose with couplers and heavy duty metal storage case

\* Must be used with 1/2" punch and die

\*\*Must be used with 3-1/2" to 4" punch and die

#### Accessories:

- BKP500B:** 1/2" Punch; 7/8" Hole; included in BKOH520A, BKOH540A, and BKOF540
- BKD500B:** 1/2" Die; 7/8" Hole; included in BKOH520A, BKOH540A, and BKOF540
- BKP750B:** 3/4" Punch; 1-3/32" Hole; included in BKOH520A, BKOH540A, and BKOF540
- BKD750B:** 3/4" Die; 1-3/32" Hole; included in BKOH520A, BKOH540A, and BKOF540
- BKP1000B:** 1" Punch; 1-11/32" Hole; included in BKOH520A, BKOH540A, and BKOF540
- BKD1000B:** 1" Die; 1-11/32" Hole; included in BKOH520A, BKOH540A, and BKOF540



**BKOH520A**

#### Accessories: (Continued)

- BKP1250B:** 1-1/4" Punch; 1-11/16" Hole; included in BKOH520A, BKOH540A, and BKOF540
- BKD1250B:** 1-1/4" Die; 1-11/16" Hole; included in BKOH520A, BKOH540A, and BKOF540
- BKP1500B:** 1-1/2" Punch; 1-15/16" Hole; included in BKOH520A, BKOH540A, and BKOF540
- BKD1500B:** 1-1/2" Die; 1-15/16" Hole; included in BKOH520A, BKOH540A, and BKOF540
- BKP2000B:** 2" Punch; 2-3/8" Hole; included in BKOH520A, BKOH540A, and BKOF540
- BKD2000B:** 2" Die; 2-3/8" Hole; included in BKOH520A, BKOH540A, and BKOF540
- BPH20:** 2 speed Hand Pump; included in BKOH520A and BKOH540A
- BKPR7540:** Drawstud for 3/4" to 4" punches/dies; included in BKOH520A, BKOH540A, and BKOF540
- BKPS50\*:** Stainless Steel Drawstud, 3/8" dia.; included in BKOH520A, BKOH540A, and BKOF540
- BKC3540\*\*:** Converter; included in BKOH520A, BKOH540A, and BKOF540
- BCH1211:** 12-ton hydraulic cylinder; included in BKOH520A, BKOH540A, and BKOF540
- BH864:** 6' rubber hose with couplers; included in BKOH520A, BKOH540A, and BKOF540
- BCM5:** Heavy duty metal carrying case; included with BKOH520A, BKOH540A and BKOF540
- BKP2500:** 2-1/2" Punch; 2-7/8" Hole; included in BKOH540A and BKOF540
- BKD2500:** 2-1/2" Die; 2-7/8" Hole; included in BKOH540A and BKOF540
- BKP3000:** 3" Punch; 3-1/2" Hole; included in BKOH540A and BKOF540
- BKD3000:** 3" Die; 3-1/2" Hole; included in BKOH540A and BKOF540
- BKP3500:** 3-1/2" Punch; 4" Hole; included in BKOH540A and BKOF540
- BKD3500:** 3-1/2" Die; 4" Hole; included in BKOH540A and BKOF540
- BKP4000:** 4" Punch; 4-1/2" Hole; included in BKOH540A and BKOF540
- BKD4000:** 4" Die; 4-1/2" Hole; included in BKOH540A and BKOF540
- BPF65:** 2 speed Foot Pump; included in BKOF540

US: 1-800-346-4175 / International: 1-603-647-5299 / Canada: 1-800-387-6487 / [www.burndy.com](http://www.burndy.com)

# Hand Benders

## Conduit Hand Benders

Heads, Handles Sold Separately or as a Kit

- All bender heads embossed with sight lines for 10°, 22°, 30°, 45°, 60° and 90°
- Industry standard markings (30° when handle is straight up)
- 3/4" and 1" bender heads have levels making aligning easy
- Designed with a channel to bend conduit back if you have an over-bend
- 5 year limited warranty

### Bender Heads Only:

- B12E** 1/2" EMT Bender Head Only
- B34E12R** 3/4" EMT; 1/2" Rigid Bender Head Only
- B1E34R** 1" EMT; 3/4" Rigid Bender Head Only

### Handles Only:

- H12E** 1/2" EMT Bender Handle Only
- H34E12R** 3/4" EMT; 1/2" Rigid Handle Only
- H1E34R** 1" EMT; 3/4" Rigid Handle Only

### Bender Head and Handle (Assembled):

- BHA12E** 1/2" EMT Bender Head and Handle Assembled
- BHA34E12R** 3/4" EMT; 1/2" Rigid Bender Head and Handle Assembled
- BHA1E34R** 1" EMT; 3/4" Rigid Bender Head and Handle Assembled



**B12E**



**B34E12R**



**B1E34R**



**Handles**

# BEB122

## Electric Conduit Bender

For 1/2" to 2" Conduit and Pipe

- Reliable electric system with no circuit boards
- Maximum schedule 40 conduit
- Can produce 180° bends in a single cycle
- Available with or without shoes, see Variations for details
- Limit stop control for bend angle settings
- Operates on 115-120 VAC 60 Hz

### Variations:

**BEB122:** Electric Bender Power Unit ONLY; without shoes and roller supports

**BEB122RIG:** Electric Bender with shoes and roller supports for 1/2" through 2" RIGID conduit, 1/2" through 1-1/2" IMC conduit, and 1/2" through 2" Schedule 40 pipe

**BEB122EMT\*:** Electric Bender with shoes and roller supports for 1/2" through 2" EMT conduit

**BEB122PVC\*:** Electric Bender with shoes and roller supports for 1/2" through 2" PVC coated RIGID conduit

\*Shoes and roller supports come with **BEBSHOECASE** metal storage box



### Accessories:

**122RIG:** Shoes and roller supports ONLY; for bending 1/2" through 2" RIGID conduit, 1/2" through 1-1/2" IMC conduit, and 1/2" through 2" Schedule 40 pipe

**122EMT\*:** Shoes and roller supports ONLY; for bending 1/2" through 2" EMT (thinwall)

**122IMC\*:** Shoes and roller supports ONLY; for bending 1-1/2" and 2" IMC

**122PVC\*:** Shoes and roller supports ONLY; for bending 1/2" through 2" 40 mil PVC coated RIGID

\*Shoes and roller supports come with **BEBSHOECASE** metal storage box

# The SmartCart®

## 2-Wheel Heavy Duty Cart

Standard Configurations or Fully Customizable

- Heavy Duty Cart - 600 lb capacity
- Base Cart has two (2) holders provided for up to 1" conduit benders
- Built-in tray to hold fish tapes/tools
- Most popular variations listed; cart and accessories are also available separately for full customization
- 1 year limited warranty

### Variations:

<b>BSC2H</b>	2-Wheel Heavy Duty Cart without racks
<b>BSC2H5A</b>	2-Wheel Heavy Duty Cart with five (5) R17A racks
<b>BSC2H3A2B</b>	2-Wheel Heavy Duty Cart with three (3) R17A racks and two (2) R22B racks
<b>BSC2H5B</b>	2-Wheel Heavy Duty Cart with five (5) R22B racks
<b>BSC2H1C2DEBP</b>	2-Wheel Heavy Duty Cart with one (1) R17C rack, two (2) R25D racks and one (1) EBP
<b>BSC2H2C1DEBP</b>	2-Wheel Heavy Duty Cart with two (2) R17C rack, one (1) R25D rack and one (1) EBP
<b>BSC2H2A1B1FEBP</b>	2-Wheel Heavy Duty Cart with two (2) R17A racks, one (1) R22B rack, one (1) R24F rack and one (1) EBP

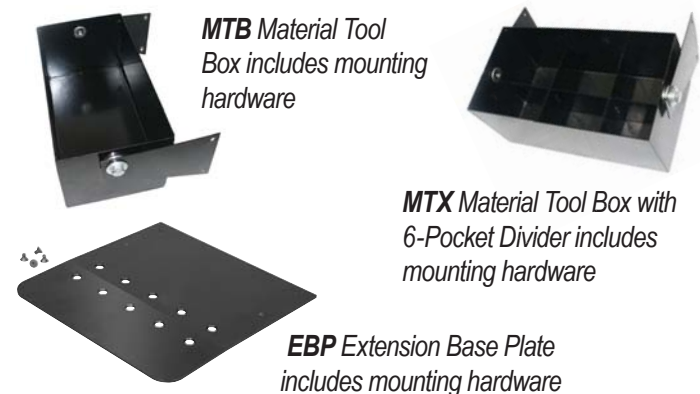

**BSC2H**

**BSC2HA1B1FEBP**

### Accessories:

<b>EPB:</b>	Extension Base Plate with built in wire guide includes mounting hardware
<b>MTB:</b>	Material Tool Box (11" x 6" x 5") includes mounting hardware
<b>MTX:</b>	Material Tool Box (MTB) with dividers into 6 pockets (3-5/8" x 3" x 3") includes mounting hardware
<b>R17A:</b>	17" wide rack for 7-1/2" diameter spools with 1/2" EMT spindles
<b>R22B:</b>	22" wide rack for 7-1/2" diameter spools with 1/2" EMT spindles
<b>R17C*:</b>	17" wide rack for 12" diameter spools with 1" EMT spindles
<b>R25D*:</b>	25" wide rack for 12" diameter spools with 1" EMT spindles
<b>R24F*:</b>	24" wide rack for two (2) 16" diameter reels with 1" EMT spindles
<b>BSCWS40:</b>	40" Wall Wire Reel Storage System; racks sold separately
<b>BSCWS80:</b>	80" Wall Wire Reel Storage System; racks sold separately

\*Note: R17C, R25D, and R24F racks are designed for oversized reels; the Extension Base Plate (EBP) is required for these racks when used with The SmartCart®



## The SmartCart®

### 2-Wheel Light Duty Cart

Standard Configurations or Fully Customizable

- Light Duty Cart - 300 lb capacity
- Base Cart has two (2) holders provided for up to 1" conduit benders
- Built-in tray to hold fish tapes/tools
- Most popular variations listed; cart and accessories are also available separately for full customization
- 1 year limited warranty

#### Variations:

<b>BSC2L</b>	2-Wheel Light Duty Cart without racks
<b>BSC2L5A</b>	2-Wheel Light Duty Cart with five (5) R17A racks
<b>BSC2L3A2B</b>	2-Wheel Light Duty Cart with three (3) R17A racks and two (2) R22B racks
<b>BSC2L5B</b>	2-Wheel Light Duty Cart with five (5) R22B racks
<b>BSC2L1C2DEBP</b>	2-Wheel Light Duty Cart with one (1) R17C rack, two (2) R25D racks and one (1) EBP
<b>BSC2L2C1DEBP</b>	2-Wheel Light Duty Cart with two (2) R17C rack, one (1) R25D rack and one (1) EBP

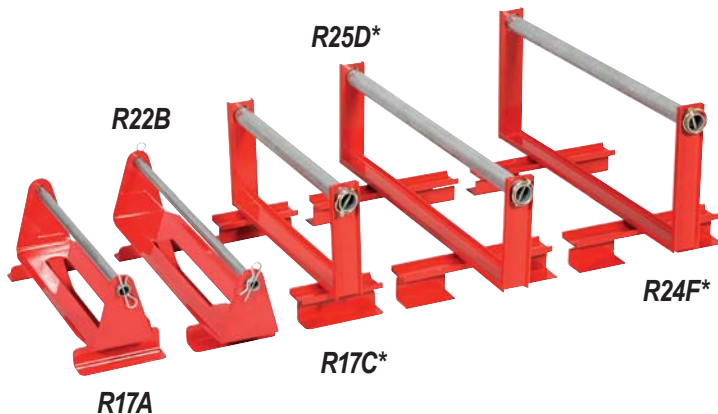

#### Accessories:

<b>EPB:</b>	Extension Base Plate with built in wire guide includes mounting hardware
<b>MTB:</b>	Material Tool Box (11" x 6" x 5") includes mounting hardware
<b>MTX:</b>	Material Tool Box (MTB) with dividers into 6 pockets (3-5/8" x 3" x 3") includes mounting hardware
<b>R17A:</b>	17" wide rack for 7-1/2" diameter spools with 1/2" EMT spindles
<b>R22B:</b>	22" wide rack for 7-1/2" diameter spools with 1/2" EMT spindles
<b>R17C*:</b>	17" wide rack for 12" diameter spools with 1" EMT spindles
<b>R25D*:</b>	25" wide rack for 12" diameter spools with 1" EMT spindles
<b>R24F*:</b>	24" wide rack for two (2) 16" diameter reels with 1" EMT spindles
<b>BSCWS40:</b>	40" Wall Wire Reel Storage System; racks sold separately
<b>BSCWS80:</b>	80" Wall Wire Reel Storage System; racks sold separately

\*Note: R17C, R25D, and R24F racks are designed for oversized reels; the Extension Base Plate (EBP) is required for these racks when used with The SmartCart®

**The SmartCart®**

**Wall Wire Reel Storage System**  
40" or 80" Variations Available; Racks Sold Separately

- Designed to work in a van, panel truck or shop
- All racks available for The SmartCart® also work with these wall storage systems
- 1 year limited warranty

**Variations:**

- BSCWS40**      40" Wall Wire Reel Storage System; racks sold separately
- BSCWS80**      80" Wall Wire Reel Storage System; racks sold separately



**BSCW40**



**BSCW80**



**BSCW80** shown with racks  
(sold separately)

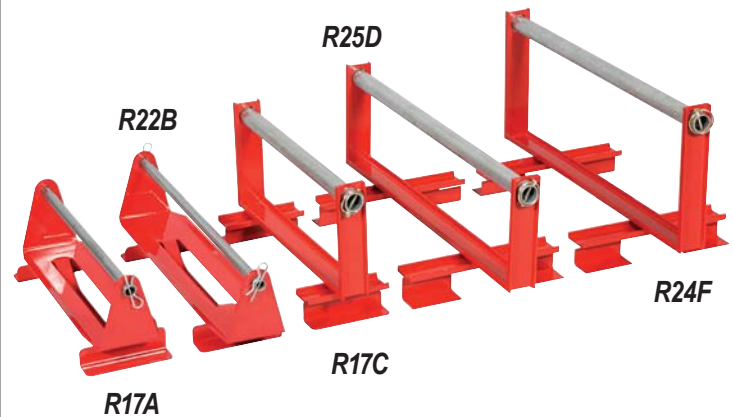

**Accessories:**

- R17A:**      17" wide rack for 7-1/2" diameter spools with 1/2" EMT spindles
- R22B:**      22" wide rack for 7-1/2" diameter spools with 1/2" EMT spindles
- R17C\*:**      17" wide rack for 12" diameter spools with 1" EMT spindles
- R25D\*:**      25" wide rack for 12" diameter spools with 1" EMT spindles
- R24F\*:**      24" wide rack for two (2) 16" diameter reels with 1" EMT spindles

\*Note: R17C, R25D, and R24F racks are designed for oversized reels; the Extension Base Plate (EBP) is required for these racks when used with The SmartCart®



The following connectors are range taking when crimped onto code and flex conductor using the 4-POINT® Series of tools:

### COPPER

Copper Conductor (Code & Compact)							
Conductor		Standard Barrel			Long Barrel		
Wire Size	Expanded Range	Terminal	Splice	# Crimps*	Terminal	Splice	# Crimps*
#8 AWG	#8 AWG	YA8CL-	YS8CL-	1	YA8C-	YS8C-	1
#6 AWG	#6 AWG	YA6CL-	YS6CL-	1	YA6C-	YS6C-	1
#4 AWG	#6 - #4 AWG	YA4CL-	YS4CL-	1	YA4C-	YS4C-	1
#2 AWG	#6 - #2 AWG	YA2CL-	YS2CL-	1	YA2C-	YS2C-	2
#1 AWG	#6 - #1 AWG	YA1CL-	YS1CL-	1	YA1C-	YS1C-	2
1/0 AWG	#6 - 1/0 AWG	YA25L-	YS25L-	1	YA25-	YS25-	2
2/0 AWG	#4 - 2/0 AWG	YA26L-	YS26L-	1	YA26-	YS26-	2
3/0 AWG	#2 - 3/0 AWG	YA27L-	YS27L-	2	YA27-	YS27-	2
4/0 AWG	#1 - 4/0 AWG	YA28L-	YS28L-	2	YA28-	YS28-	2
250 kcmil	1/0 AWG - 250 kcmil	YA29L-	YS29L-	2	YA29-	YS29-	2
300 kcmil	2/0 AWG - 300 kcmil	YA30L-	YS30L-	2	YA30-	YS30-	3
350 kcmil	3/0 AWG - 350 kcmil	YA31L-	YS31L-	2	YA31-	YS31-	3
400 kcmil	4/0 AWG - 400 kcmil	YA32L-	YS32L-	2	YA32-	YS32-	3
500 kcmil	4/0 AWG - 500 kcmil	YA34L-	YS34L-	2	YA34-	YS34-	4
600 kcmil	250 - 600 kcmil	YA36L-	YS36L-	2	YA36-	YS36-	4
700 kcmil	350 - 700 kcmil	YA38L-	YS38L-	3	YA38-	YS38-	4
750 kcmil	500 - 750 kcmil	YA39L-	YS39L-	3	YA39-	YS39-	4
800 kcmil	500 - 800 kcmil	YA40L-	YS40L-	3	YA40-	YS40-	4
1000 kcmil	750 - 1000 kcmil	YA44L-	YS44L-	3	YA44-	YS44-	4

### ALUMINUM

Aluminum & Copper Conductor (Code & Compact)				
Conductor		Connector		
Wire Size	Expanded Range	Terminal	Splice	# Crimps*
#8 AWG	#8 AWG	YA8CA-	YS8CA-	1
#6 AWG	#6 AWG	YA6CA-	YS6CA-	1
#4 AWG	#6 - #4 AWG	YA4CA-	YS4CA-	1
#2 AWG	#6 - #2 AWG	YA2CA-	YS2CA-	2
#1 AWG	#6 - #1 AWG	YA1CA-	YS1CA-	2
1/0 AWG	#6 - 1/0 AWG	YA25A-	YS25A-	2
2/0 AWG	#4 - 2/0 AWG	YA26A-	YS26A-	2
3/0 AWG	#2 - 3/0 AWG	YA27A-	YS27A-	2
4/0 AWG	#1 - 4/0 AWG	YA28A-	YS28A-	2
250 kcmil	1/0 AWG - 250 kcmil	YA29A-	YS29A-	2
300 kcmil	2/0 AWG - 300 kcmil	YA30A-	YS30A-	2
350 kcmil	3/0 AWG - 350 kcmil	YA31A-	YS31A-	3
400 kcmil	4/0 AWG - 400 kcmil	YA32A-	YS32A-	4
500 kcmil	4/0 AWG - 500 kcmil	YA34A-	YS34A-	4
600 kcmil	250 - 600 kcmil	YA36A-	YS36A-	4
750 kcmil	500 - 750 kcmil	YA39A-	YS39A-	4

### AYP/AYPO CONNECTORS

(Aluminum and Copper — Code & Compact)				
Wire Size	Expanded Range	Pin		# Crimps*
		Straight	Offset	
#6 AWG	#6 AWG	AYP6	—	1
#4 AWG	#4 AWG	AYP4	—	1
#2 AWG	#4 - #2 AWG	AYP2	—	1
#1 AWG	#2 - #1 AWG	AYP1	—	1
1/0 AWG	#2 - 1/0 AWG	AYP1/0	—	1
2/0 AWG	#1 - 2/0 AWG	AYP2/0	AYPO2/0	2
3/0 AWG	1/0 - 3/0 AWG	AYP3/0	AYPO3/0	2
4/0 AWG	2/0 - 4/0 AWG	AYP4/0	AYPO4/0	2
250 kcmil	3/0 - 250 kcmil	AYP250	AYPO250	2
300 kcmil	4/0 - 300 kcmil	AYP300	AYPO300	2
350 kcmil	250 - 350 kcmil	AYP350	AYPO350	2
400 kcmil	350 - 500 kcmil	AYP400	AYPO400	2
500 kcmil	350 - 500 kcmil	AYP500	AYPO500	2
600 kcmil	400 - 600 kcmil	AYP600	AYPO600	3
750 kcmil	500 - 750 kcmil	AYP750	AYPO750	3

\*Same number of recommended crimps for both Standard and Expanded wire ranges

**US: 1-800-346-4175 / International: 1-603-647-5299 / Canada: 1-800-387-6487 / www.burndy.com**

# Tooling

## Expanded Cable Range



The following connectors are range taking when crimped onto code and flex conductor using 4-POINT® Series of tools:  
(continued from previous page)

Copper Conductor (Flex Only)							
Nom. Flex Wire Size	Expanded Range	Standard Barrel			Long Barrel		
		Terminal	Splice	# Crimps*	Terminal	Splice	# Crimps*
#8 AWG	#8 AWG	YAV8CL-	YSV8CL-	1	YAV8C-	YSV8C-	1
#6 AWG	#6 AWG	YAV6CL-	YSV6CL-	1	YAV6C-	YSV6C-	1
#4 AWG	#6 - #4 AWG	YAV4CL-	YSV4CL-	1	YAV4C-	YSV4C-	1
#2 AWG	#6 - #2 AWG	YAV2CL-	YSV2CL-	1	YAV2C-	YSV2C-	1
#1 AWG	#4 - #1 AWG	YAV1CL-	YSV1CL-	1	YAV1C-	YSV1C-	1
1/0 AWG	#4 - 1/0 AWG	YAV25L-	YSV25L-	1	YAV25-	YSV25-	2
2/0 AWG	#2 - 2/0 AWG	YAV26L-	YSV26L-	1	YAV26-	YSV26-	2
3/0 AWG	#1 - 3/0 AWG	YAV27L-	YSV27L-	1	YAV27-	YSV27-	2
4/0 AWG	1/0 - 4/0 AWG	YAV28L-	YSV28L-	1	YAV28-	YSV28-	2
250 kcmil	3/0 AWG - 250 kcmil	YAV29L-	YS29L-	1	YAV29-	YS29-	2
300 kcmil	4/0 AWG - 313.1 kcmil	YA32L-	YS32L-	1	YA32-	YS32-	2
350 kcmil	250 - 373.7 kcmil	YA34L-	YS34L-	1	YA34-	YS34-	2
450 kcmil	250 - 444.4 kcmil	YA36L-	YS36L-	1	YA36-	YS36-	2
500 kcmil	373.7 - 535.3 kcmil	YA38L-	YS38L-	1	YA38-	YS38-	2
600 kcmil	373.7 - 600 kcmil	YA39L-	YS39L-	2	YA39-	YS39-	3
650 kcmil	444.4 - 646 kcmil	YA40L-	YS40L-	2	YA40-	YS40-	3
750 kcmil	535.3 - 777.7 kcmil	YA44L-	YS44L-	2	YA44-	YS44-	3



Y81KFTMBH

Expanded conductor ranges shown are applicable when using the 4-POINT® Series of tools only.  
(Continued from previous page.)

E-Line Connectors							
Wire Size	Expanded Wire Range	Aluminum			Copper		
		Offset	Center formed	# Crimps*	Offset	Center formed	# Crimps*
#8 AWG	#8 AWG	YA8CA-T-E		1			
#6 AWG	#6 AWG						
#4 AWG	#6 - #4 AWG						
#2 AWG	#6 - #2 AWG	YA2CA-T-E	YAC2CA-T-E	1			
#1 AWG	#6 - #1 AWG						
1/0 AWG	#6 - 1/0 AWG	YA25A-T-E		1	YA25L-T-E	YAC25L-T-E	1
2/0 AWG	#4 - 2/0 AWG	YA26A-T-E		2	YA26L-T-E	YAC26L-T-E	1
3/0 AWG	#2 - 3/0 AWG	YA27A-T-E	YAC27A-T-E	2			
4/0 AWG	#1 - 4/0 AWG	YA28A-T-E		2			
250 kcmil	1/0 AWG - 250 kcmil						
300 kcmil	2/0 AWG - 300 kcmil	YA30A-T-E		2	YA30L-T-E	YAC30L-T-E	2
350 kcmil	3/0 AWG - 350 kcmil	YA31A-T-E	YAC31A-T-E	2			
400 kcmil	4/0 AWG - 400 kcmil	YA32A-T-E		4			
500 kcmil	4/0 AWG - 500 kcmil	YA34A-T-E		4	YA34L-T-E		2
500 kcmil	4/0 AWG - 500 kcmil				YA342L-T-E		2
600 kcmil	250 - 600 kcmil	YA36A-T-E		4	YA36L-T-E		2
600 kcmil	250 - 600 kcmil				YA362L-T-E		2
700 kcmil	350 - 700 kcmil						
750 kcmil	500 - 750 kcmil	YA39A-T-E		4	YA39L-T-E		2
750 kcmil	500 - 750 kcmil				YA392L-T-E		2
800 kcmil	500 - 800 kcmil						
1000 kcmil	750 - 1000 kcmil						

\*Same number of recommended crimps for both Standard and Expanded wire ranges

US: 1-800-346-4175 / International: 1-603-647-5299 / Canada: 1-800-387-6487 / www.burndy.com



The following connectors are range taking when crimped onto code conductor using Y644 Series of tools:

## COPPER

Copper HYLUG™ & HYLINK™ Connectors Types YA, YA-L, YAB, YS, YS-L, YST, YS-T, YSP-T			
Catalog No.		Standard Wire Size	Expanded Wire Range
Terminal*	Splice**		
YA6C- YA5C- YA4C- YA3C- YA2C- YA1C-	YS6C- YS5C- YS4C- YS3C- YS2C- YS1C-	#6 AWG #5 AWG #4 AWG #3 AWG #2 AWG #1 AWG	#6 AWG #6 - #5 AWG #6 - #4 AWG #6 - #3 AWG #6 - #2 AWG #6 - #1 AWG
YA25- YA26- YA27- YA28-	YS25- YS26- YS27- YS28-	1/0 AWG 2/0 AWG 3/0 AWG 4/0 AWG	#6 - 1/0 AWG #4 - 2/0 AWG #2 - 3/0 AWG #1 - 4/0 AWG
YA29- YA30- YA31- YA32- YA34-	YS29- YS30- YS31- YS32- YS34-	250 kcmil 300 kcmil 350 kcmil 400 kcmil 500 kcmil	1/0 AWG - 250 kcmil 2/0 AWG - 300 kcmil 3/0 AWG - 350 kcmil 4/0 AWG - 400 kcmil 4/0 AWG - 500 kcmil
YA36- YA39- YA40-	YS36- YS39- YS40-	600 kcmil 750 kcmil 800 kcmil	250 - 600 kcmil 500 - 750 kcmil 500 - 800 kcmil
YA44-	YS44-	1000 kcmil	750 - 1000 kcmil

\* 1 Crimp  
\*\* 1 Crimp per side

## ALUMINUM

Aluminum HYLUG™ & HYLINK™ Connectors Types YA-A & YS-A (Copper or Aluminum Conductor)			
Catalog No.		Standard Wire Size	Expanded Wire Range
Terminal*	Splice**		
YA6CA- YA4CA- YA2CA- YA1CA-	YS6CA- YS4CA- YS2CA- YS1CA-	#6 AWG #4 AWG #2 AWG #1 AWG	#6 AWG #6 - #4 AWG #6 - #2 AWG #2 - #1 AWG
YA25A- YA26A- YA27A- YA28A-	YS25A- YS26A- YS27A- YS28A-	1/0 AWG 2/0 AWG 3/0 AWG 4/0 AWG	#1 - 1/0 AWG #1 - 2/0 AWG #1 - 3/0 AWG #1 - 4/0 AWG
YA29A- YA30A- YA31A- YA32A- YA34A-	YS29A- YS30A- YS31A- YS32A- YS34A-	250 kcmil 300 kcmil 350 kcmil 400 kcmil 500 kcmil	1/0 AWG - 250 kcmil 2/0 AWG - 300 kcmil 3/0 AWG - 350 kcmil 4/0 AWG - 400 kcmil 4/0 AWG - 500 kcmil
YA36A- YA39A-	YS36A- YS39A-	600 kcmil 750 kcmil	250 - 600 kcmil 500 - 750 kcmil

\* 1 Crimp  
\*\* 1 Crimp per side

*Expanded conductor ranges shown on this page are applicable when using the Y644/PAT644 Series of tools only.*



Y644MBH

## PRESENT INSTALLATION TOOL INDEX

This chart provides a cross-reference between die index numbers marked on **BURNDY Compression Connectors** and the corresponding **BURNDY Die Sets** used with the various **BURNDY Installation Tools**. This is the only way to have a complete connections with the **BURNDY® ENGINEERED SYSTEM**.

A die index number has been assigned to each required groove configuration. A prefix letter is used to indicate the specific installation tool for which the die has been designed, as shown.

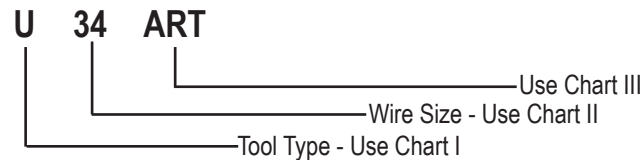
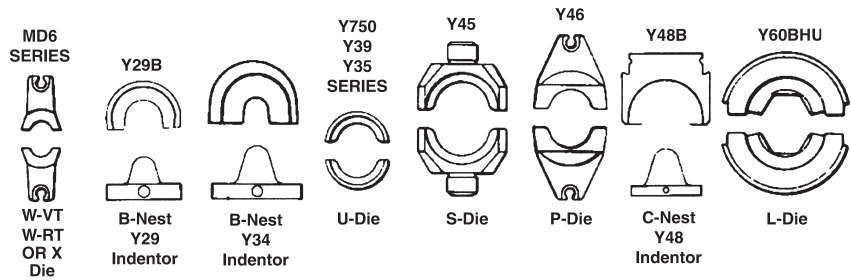

CHART I			
A = Y34A	E = Y48B	P = Y46	X = OUR840/MD6
B = Y34BH	F = Y486RB	S = Y45	
C = Y48B	G = Y34C	U = Y35	
	L = Y60	W = MD6/OUR840	

CHART II			
12 = #12	4C = #4	26 = 2/0	31 = 350 kcmil
10 = #10	3C = #3	27 = 3/0	32 = 400 kcmil
8C = #8	2C = #2	28 = 4/0	34 = 500 kcmil
6C = #6	1C = #1	29 = 250 kcmil	36 = 600 kcmil
5C = #5	25 = 1/0	30 = 300 kcmil	39 = 750 kcmil
			44 = 1000 kcmil

OR INDEX NUMBER: i.e. U312 = 312 Die Index

CHART III
A = ALUMINUM
B = INDENTOR NEST (used with indentor die #Y34P**)
R = ROUND (circumferential)
T = TWIN DIE (both halves)

### Footnotes for the chart in the following pages:

- ① Cat. No. Y35P3 Adaptor is required to use "Y34PR" type indentors with "U" type nest dies in Y35 and Y750 series.
- ② Cat. No. PT6515 Adaptor is required to use "U" type dies in Y45 series.
- ③ Cat. No. PUADP-1 Adaptor is required to use "U" type dies in Y46 series.
- ④ The MD6-6R2 ratchet tool is required on these sizes. The standard MD6 or MD6R ratchet tools will not work.
- ⑤ Also pneumatic version Y29NC.
- ⑥ Die 302 recommended for 1.84 O.D. barrel.
- ⑦ Hexagonal crimp

**PRESENT INSTALLATION TOOL INDEX (continued)**

DIE		DIELESS TOOLS		INSTALLATION TOOLING USING DIES										
GROOVE		MECH.	HYD.	DIE INFORMATION		MECHANICAL		HYDRAULIC						
BURNDY	EEI	MR, MY	Y644	TYPE	COLOR	MD6	OUR840	Y29B <sup>Ⓢ</sup>	Y35 <sup>①</sup>	Y39	Y750 <sup>①</sup>	Y45 <sup>②</sup>	Y46 <sup>③</sup>	Y60 Ser.
A				DIE SET					U-A	U-A	U-A	U-A	U-A	
BG				DIE SET		Perm. GR W-BG	X-BG X-NBG		U-BG	U-BG	U-BG	U-BG	U-BG	
C				DIE SET	BROWN	W-C			U-C	U-	U-C	U-C	U-C	
D				DIE SET					U-D	U-D	U-D	U-D	U-D	
D3				DIE SET	BLUE				U-YFD	U-YFD	U-YFD	U-YFD	U-YFD	
						Perm. GR			U-D3	U-D3	U-D3	U-D3	U-D3	
E				DIE SET					U-E	U-E	U-E	U-E	U-E	
F				DIE SET					U-F	U-F	U-F	U-F	U-F	
H				DIE SET					U-H	U-H	U-H	U-H	U-H	
K-1/4				DIE SET		WK14								
K-5/16				DIE SET		WK516			UK516T	UK526T	UK516T	UK516T	UK516T	
K-3/8				DIE SET		WK38			UK38T	UK38T	UK38T	UK38T	UK38T	
K-1/2				DIE SET		WK12								
K-9/16				DIE SET		WK916			UK916T	UK916T	UK916T	UK916T	UK916T	
K-19/32				DIE SET		WK1932								
K-5/8-1				DIE SET					UK581T	UK581T	UK581T	UK581T	UK581T	
K-11/16				DIE SET		WK1116			UK1116T	UK1116T	UK1116T	UK1116T	UK1116T	
K-3/4				DIE SET					UK34T	UK34T	UK34T	UK34T	UK34T	
K-1				DIE SET					UK1T	UK1T	UK1T	UK1T	UK1T	
K-1-5/16				DIE SET					UK1516T	UK1516T	UK1516T	UK1516T	UK1516T	
K-635				DIE SET		WK737			UK737T	UK737T	UK737T	UK737T	UK737T	
K-747				DIE SET		WK747								
K-781				DIE SET		WK781								
K-840				DIE SET		W-K840			U-K840	U-K840	U-K840	U-K840	U-K840	
KB				DIE SET		WKB			UKBT	UKBT	UKBT	UKBT	UKBT	
KBKT				DIE SET					UKBKTT	UKBKTT	UKBKTT	UKBKTT	UKBKTT	
KC				DIE SET					UKCT	UKCT	UKCT	UKCT	UKCT	
KK				DIE SET		WKK								
KR				DIE SET	YELLOW									P-YFR
												S-KR	P-KR	
KT				DIE SET		WKT								
KU				DIE SET					UKUT	UKUT	UKUT	UKUT	UKUT	
L				DIE SET		W-L			U-L	U-L	U-L	U-L	U-L	
L80				DIE SET					U32XRT	U32XRT	U32XRT	U32XRT	U32XRT	
L99				DIE SET	PINK				U38XRT	U38XRT	U38XRT	U38XRT	U38XRT	
L115				DIE SET	YELLOW				U44XRT	U44XRT	U44XRT	U44XRT	U44XRT	
M				DIE SET					U-M	U-M	U-M	U-M	U-M	
N				DIE SET	RED				U-YFN	U-YFN	U-YFN	U-YFN	U-YFN	
									U-N	U-N	U-N	U-N	U-N	
O				DIE SET	GREEN				U-YFO	U-YFO	U-YFO	U-YFO	U-YFO	
						Perm. GR W-O			U-O	U-O	U-O	U-O	U-O	
Q				DIE SET		W-Q								
R				DIE SET					U-R	U-R	U-R	U-R	U-R	

**PRESENT INSTALLATION TOOL INDEX (continued)**

DIE		DIELESS TOOLS		INSTALLATION TOOLING USING DIES										
GROOVE		MECH.	HYD.	DIE INFORMATION		MECHANICAL		HYDRAULIC						
BURNDY	EEL	MR, MY	Y644	TYPE	COLOR	MD6	OUR840	Y29B ⑤	Y35 ①	Y39	Y750 ①	Y45 ②	Y46 ③	Y60 Ser.
T				DIE SET								S-T		
Z				DIE SET								S-Z		
7 94		MR4C MY29-3 MY29-11	1 CRIMP	DIE SET	BLUE	W5CRT	X5CRT		U5CRT	U5CRT	U5CRT	U5CRT	U5CRT	U5CRT
				NEST				D6CL	U6CD-1	U6CD-1	U6CD-1	U6CD-1	U6CD-1	
				INDENTOR				Y29PR	Y34PR	Y34PR	Y34PR	Y34PR	Y34PR	
8 95		MR4C MY29-3 MY29-11	1 CRIMP	DIE SET	GRAY	W4CRT	X4CRT		U4CRT	U4CRT	U4CRT	U4CRT	U4CRT	
				NEST				D4CL	U4CD-1	U4CD-1	U4CD-1	U4CD-1	U4CD-1	
				INDENTOR				Y29PR	Y34PR	Y34PR	Y34PR	Y34PR	Y34PR	
9 96		MY29-3 MY29-11	1 CRIMP	DIE SET	WHITE	W3CRT	X3CRT		U3CRT	U3CRT	U3CRT	U3CRT	U3CRT	
				NEST				D3CL	U3CD-1	U3CD-1	U3CD-1	U3CD-1	U3CD-1	
				INDENTOR				Y29PR	Y34PR	Y34PR	Y34PR	Y34PR	Y34PR	
10 97		MY29-3 MY29-11	1 CRIMP	DIE SET	BROWN	W2CRT	X2CRT		U2CRT	U2CRT	U2CRT	U2CRT	U2CRT	
				NEST				D2CL	U2CD-1	U2CD-1	U2CD-1	U2CD-1	U2CD-1	
				INDENTOR				Y29PR	Y34PR	Y34PR	Y34PR	Y34PR	Y34PR	
11 98		MY29-3 MY29-11	1 CRIMP	DIE SET	GREEN	W1CRT-1	X1CRT-1		U1CRT-1	U1CRT-1	U1CRT-1	U1CRT-1	U1CRT-1	
				NEST				D1CL	U1CD-1	U1CD-1	U1CD-1	U1CD-1	U1CD-1	
				INDENTOR				Y29PR	Y34PR	Y34PR	Y34PR	Y34PR	Y34PR	
12 99		MY29-3 MY29-11	1 CRIMP	DIE SET	PINK	W25RT	X25RT		U25RT	U25RT	U25RT	U25RT	U25RT	
				NEST				D25L	U25D-1	U25D-1	U25D-1	U25D-1	U25D-1	
				INDENTOR				Y29PR	Y34PR	Y34PR	Y34PR	Y34PR	Y34PR	
13 100		MY29-3 MY29-11	1 CRIMP	DIE SET	BLACK	W26RT	X26RT		U26RT	U26RT	U26RT	U26RT	U26RT	
				NEST				D26L	U26D-1	U26D-1	U26D-1	U26D-1	U26D-1	
				INDENTOR				Y29PR	Y34PR	Y34PR	Y34PR	Y34PR	Y34PR	
14 101		MY29-3 MY29-11	1 CRIMP	DIE SET	ORANGE	W27RT	X27RT		U27RT	U27RT	U27RT	U27RT	U27RT	
				NEST				D27L	U27D-1	U27D-1	U27D-1	U27D-1	U27D-1	
				INDENTOR				Y29PR	Y34PR	Y34PR	Y34PR	Y34PR	Y34PR	
15		MY29-3 MY29-11	1 CRIMP	DIE SET	PURPLE	W28RT	X28RT		U28RT	U28RT	U28RT	U28RT	U28RT	
				NEST				D28L	U28D-1	U28D-1	U28D-1	U28D-1	U28D-1	
				INDENTOR				Y29PR	Y34PR	Y34PR	Y34PR	Y34PR	Y34PR	
16		MY29-3 MY29-11	1 CRIMP	DIE SET	YELLOW	W29RT④	X29RT		U29RT	U29RT	U29RT	U29RT	U29RT	
				NEST				D29L		U29D-1	U29D-1	U29D-1	U29D-1	
				INDENTOR				Y29PR		Y34PR	Y34PR	Y34PR	Y34PR	
17			1 CRIMP	DIE SET	WHITE	W30RT④			U30RT	U30RT	U30RT	U30RT	U30RT	L30RT
				NEST						U30D-1	U30D-1	U30D-1	U30D-1	
				INDENTOR						Y34PR	Y34PR	Y34PR	Y34PR	
18			1 CRIMP	DIE SET	RED	W31RT④			U31RT	U31RT	U31RT	U31RT	U31RT	L31RT
				NEST						U31D-1	U31D-1	U31D-1	U31D-1	
				INDENTOR						Y34PR	Y34PR	Y34PR	Y34PR	
19			1 CRIMP	DIE SET	BLUE	W32RT④			U32RT	U32RT	U32RT	U32RT	U32RT	L32RT
				NEST						U32D-1	U32D-1	U32D-1	U32D-1	
				INDENTOR						Y34PR	Y34PR	Y34PR	Y34PR	
20			1 CRIMP	DIE SET	BROWN	W34RT④			U34RT	U34RT	U34RT	U34RT	U34RT	L34RT
				NEST						U34D-1	U34D-1	U34D-1	U34D-1	
				INDENTOR						Y34PR	Y34PR	Y34PR	Y34PR	



**PRESENT INSTALLATION TOOL INDEX (continued)**

DIE		DIELESS TOOLS		INSTALLATION TOOLING USING DIES											
GROOVE		MECH.	HYD.	DIE INFORMATION		MECHANICAL		HYDRAULIC							
BURNDY	EEI	MR, MY	Y644	TYPE	COLOR	MD6	OUR840	Y29B ⑤	Y35 ①	Y39	Y750 ①	Y45 ②	Y46 ③	Y60 Ser.	
21			1 CRIMP	DIE SET	YELLOW					U35RT	U35RT	U35RT	U35RT		
				NEST											
				INDENTOR											
22			1 CRIMP	DIE SET	GREEN					U36RT	U36RT	U36RT	U36RT	L36RT	
				NEST									P36D		
				INDENTOR									P44PR		
23			1 CRIMP	DIE SET	ORANGE					U37RT	U37RT	U37RT	U37RT		
				NEST											
				INDENTOR											
24			1 CRIMP	DIE SET	BLACK					U39RT	U39RT	S39RT	P39RT	L39RT	
				NEST									P39D		
				INDENTOR									P44PR		
25			1 CRIMP	DIE SET	ORANGE							S40RT	P40RT		
				NEST										P40D	
				INDENTOR										P44PR	
26			1 CRIMP	DIE SET	GOLD										
				NEST											
				INDENTOR											
27			1 CRIMP	DIE SET	WHITE							S44RT	P44RT	L44RT	
				NEST										P44D	
				INDENTOR										P44PR	
29				DIE SET	YELLOW								P45RT	L45RT	
				NEST											
				INDENTOR											
30				DIE SET	ORANGE										
				NEST											
				INDENTOR											
31				DIE SET	GREEN							S46RT	P46RT	L46RT	
				NEST										No Nest	
				INDENTOR										P44PR	
33				DIE SET	GRAY									L47RT	
				NEST											
				INDENTOR											
34				DIE SET	BROWN									L48RT	
				NEST											
				INDENTOR											
38		MR4C MR8G98 MR89Q MY28 Y8MRB-1		NEST				DV8L	UV8L	UV8L	UV8L	UV8L	UV8L		
				INDENTOR				Y29PL	Y34PL	Y34PL	Y34PL	Y34PL	Y34PL		
39		MR4C MY28	1 CRIMP	NEST				DV6L	UV6L	UV6L	UV6L	UV6L	UV6L		
				INDENTOR				Y29PL	Y34PLA	Y34PLA	Y34PLA	Y34PLA	Y34PLA		
40		MR4C MY28		NEST				DV4L	UV4L	UV4L	UV4L	UV4L	UV4L		
				INDENTOR				Y29PL	Y34PLA	Y34PLA	Y34PLA	Y34PLA	Y34PLA		

PRESENT INSTALLATION TOOL INDEX (continued)

DIE		DIELESS TOOLS		INSTALLATION TOOLING USING DIES										
GROOVE		MECH.	HYD.	DIE INFORMATION		MECHANICAL		HYDRAULIC						
BURNDY	E EI	MR, MY	Y644	TYPE	COLOR	MD6	OUR840	Y29B ⑤	Y35 ①	Y39	Y750 ①	Y45 ②	Y46 ③	Y60 Ser.
41		MY28		NEST				DV2L	UV2;	UV2;	UV2;	UV2;	UV2;	
				INDENTOR				Y29PL	Y34PLA	Y34PLA	Y34PLA	Y34PLA	Y34PLA	
42		MY28		NEST				DV1L	UV1L	UV1L	UV1L	UV1L	UV1L	
				INDENTOR				Y29PL	Y34PLA	Y34PLA	Y34PLA	Y34PLA	Y34PLA	
43		MY28		NEST				DV25L	UV25L	UV25L	UV25L	UV25L	UV25L	
				INDENTOR				Y29PL	Y34PA	Y34PA	Y34PA	Y34PA	Y34PA	
44		MY28		NEST				DV26L	UV26L	UV26L	UV26L	UV26L	UV26L	
				INDENTOR				Y29PL	Y34PA	Y34PA	Y34PA	Y34PA	Y34PA	
45		MY28		NEST					UV27L	UV27L	UV27L	UV27L	UV27L	
				INDENTOR					Y34PA	Y34PA	Y34PA	Y34PA	Y34PA	
46		MY28		NEST					UV28L	UV28L	UV28L	UV28L	UV28L	
				INDENTOR					Y34PA	Y34PA	Y34PA	Y34PA	Y34PA	
49				DIE SET	RED	W8CRT	X8CRT		U8CRT	U8CRT	U8CRT	U8CRT	U8CRT	
161				DIE SET		W161	X-161		U161	U161	U161	U161	U161	
162				DIE SET		W162	W162		U162	U162	U162	U162	U162	
163 505				DIE SET		W163	W163		U163	U163	U163	U163	U163	
164 275				DIE SET		W164			U164	U164	U164	U164	U164	
165 205 287 339				DIE SET		W165	X-165		U165/ U205	U165/ U205	U165/ U205	U165/ U205	U165/ U205	L165
166 206 459				DIE SET		W166			U166/ U459	U166/ U459	U166/ U459	U166/ U459	U166/ U459	L166
167 207 211 256 568				DIE SET		W167			U167/ U568	U167/ U568	U167/ U568	U167/ U568	U167/ U568	L167
168 208				DIE SET					U168	U168	U168	U168	U168	L168
169				DIE SET					U169	U169	U169	U169	U169	L169
170 306				DIE SET					U170	U170	U170	U170	U170	L170
171				DIE SET		W161			U171	U171	U171	U171	U171	
193				DIE SET					U193	U193	U193	U193	U193	L193
202				DIE SET					U202	U202	U202	U202	U202	
203				DIE SET					U203	U203	U203	U203	U203	
204				DIE SET					U204	U204	U204	U204	U204	
205 165 287 339				DIE SET		W165	X-165		U165/ U205	U165/ U205	U165/ U205	U165/ U205	U165/ U205	L165
206 166 459				DIE SET		W166			U166/ U459	U166/ U459	U166/ U459	U166/ U459	U166/ U459	L166
207 167 211 256 568				DIE SET		W167			U167/ U568	U167/ U568	U167/ U568	U167/ U568	U167/ U568	L167
208 168				DIE SET					U168	U168	U168	U168	U168	L168
209				DIE SET					U209	U209	U209	U209	U209	L209
210				DIE SET					U210	U210	U210	U210	U210	L210
211 167 256 568				DIE SET		W167			U167/ U568	U167/ U568	U167/ U568	U167/ U568	U167/ U568	L167
236				DIE SET		W236			U236	U236	U236	U236	U236	
237				DIE SET		W237	X-237		U237	U237	U237	U237	U237	
238				DIE SET		W238			U238	U238	U238	U238	U238	

**PRESENT INSTALLATION TOOL INDEX (continued)**

DIE		DIELESS TOOLS		INSTALLATION TOOLING USING DIES										
GROOVE		MECH.	HYD.	DIE INFORMATION		MECHANICAL		HYDRAULIC						
BURNDY	EEI	MR, MY	Y644	TYPE	COLOR	MD6	OUR840	Y35 ①	Y39	Y750 ①	Y45 ②	Y46 ③	Y60 Ser.	
239				DIE SET		W239	X-239	U239	U239	U239	U239	U239		
240				DIE SET	RED	W240		U240	U240	U240	U240	U240		
241				DIE SET		W241	X-241	U241	U241	U241	U241	U241		
242 244	3S/4S			DIE SET		W242		U242	U242	U242	U242	U242	L242	
243				DIE SET		W243		U243	U243	U243	U243	U243	L243	
244 242	3S/4S			DIE SET		W242		U242	U242	U242	U242	U242	L242	
245	9A			DIE SET		W245	X-245	U245	U245	U245	U245	U245	L245	
246 248	5S			DIE SET		W248		U248	U248	U248	U248	U248	L248	
247				DIE SET		W247	X-247	U247	U247	U247	U247	U247	L247	
248 246	5S			DIE SET		W248		U248	U248	U248	U248	U248	L248	
249	11A			DIE SET		W249	X-249	U249	U249	U249	U249	U249	L249	
250				DIE SET				U250	U250	U250	U250	U250	L250	
251	12A			DIE SET	RED	W251		U251	U251	U251	U251	U251	L251	
252				DIE SET				U252	U252	U252	U252	U252	L252	
253				DIE SET				U253	U253	U253	U253	U253	L253	
254				DIE SET							S254	P254	L254	
255				DIE SET				U255	U255	U255	U255	U255	L255	
256 167 207 211 568				DIE SET		W167		U167/ U567	U167/ U567	U167/ U567	U167/ U567	U167/ U567	L167	
257				DIE SET				U257	U257	U257	U257	U257	L257	
259				DIE SET				U259	U259	U259	U259	U259		
260				DIE SET									L260	
261 318	15A			DIE SET				U261	U261	U261	U261	U261	L261	
263				DIE SET				U263	U263	U263	U263	U263		
267				DIE SET				U267	U267	U267	U267	U267	L267	
275 164				DIE SET		W164		U164	U164	U164	U164	U164		
276				DIE SET				U276	U276	U276	U276	U276		
285				DIE SET				U285	U285	U285	U285	U285		
287 165 205 339				DIE SET		W165		U165/ U205	U165/ U205	U165/ U205	U165/ U205	U165/ U205	L165	
292 578				DIE SET							S292	P292	L292	
293 294				DIE SET							S293	P293	L293	
296		MY29-3	1 CRIMP	DIE SET	TAN		X25ART	U25ART	U25ART	U25ART	U25ART			
				NEST						P27D				
				INDETOR						P34PR5				
297		MY29-3	1 CRIMP	DIE SET	OLIVE		X26ART	U26ART	U26ART	U26ART	U26ART			
				NEST						P29D				
				INDENTOR						P34PR5				
298		MY29-3	1 CRIMP	DIE SET	WHITE		X28ART	U28ART	U28ART	U28ART	U28ART	U28ART	L28ART	
				NEST								P31D		
				INDENTOR								Y45PR5		
299			1 CRIMP	DIE SET	BROWN			U31ART	U31ART	U31ART	U31ART	U31ART	L31ART	
				NEST									P35D	
				INDENTOR									P48PR1	

PRESENT INSTALLATION TOOL INDEX (continued)

DIE		DIELESS TOOLS		INSTALLATION TOOLING USING DIES									
GROOVE		MECH.	HYD.	DIE INFORMATION		MECHANICAL		HYDRAULIC					
BURNDY	EEI	MR, MY	Y644	TYPE	COLOR	MD6	OUR840	Y35 ①	Y39	Y750 ①	Y45 ②	Y46 ③	Y60 Ser.
300			1 CRIMP	DIE SET	PINK			U34ART	U34ART	U34ART	U34ART	U34ART	L34ART
				NEST							P39D		
				INDENTOR								P49PR1	
301			1 CRIMP	DIE SET	RED						S39ART	P39ART	L39ART
				NEST								P45D	
				INDENTOR								P48PR1	
302			1 CRIMP	DIE SET	BROWN						S44ART	P44ART	L44ART
				NEST								No Nest	
				INDENTOR								P48PR1	
303				DIE SET	GRAY			U42ART	U42ART	U42ART	U42ART	U42ART	
304				DIE SET				U304	U304	U304	U304	U304	L304
305 341				DIE SET				U305	U305	U305	U305	U305	L305
306 170				DIE SET				U170	U170	U170	U170	U170	L170
308				DIE SET				U308	U308	U308	U308	U308	
313				DIE SET				U313	U313	U313	U313	U313	L313
314 376				DIE SET									L314
316				DIE SET				U316	U316	U316	U316	U316	L316
317 426				DIE SET				U317	U317	U317	U317	U317	L317
318 261				DIE SET				U261	U261	U261	U261	U261	L261
319				DIE SET							S319	P319	L319
320				DIE SET							S320	P320	L320
321				DIE SET				U321	U321	U321	U321	U321	L321
322				DIE SET				U322	U322	U322	U322	U322	
324			1 CRIMP	DIE SET	RED			U29ART	U29ART	U29ART	U29ART	U29ART	L29ART
				NEST								P32D	
				INDENTOR								P34PR5	
326 538				DIE SET				U33RT	U33RT	U33RT	U33RT	U33RT	
327	14A			DIE SET				U327	U327	U327	U327	U327	L327
328				DIE SET									L328
329				DIE SET				U329	U329	U329	U329	U329	
331				DIE SET				U331	U331	U331	U331	U331	
339 165 205 287				DIE SET			X-339	U165/ U205	U165/ U205	U165/ U205	U165/ U205	U165/ U205	
341 305				DIE SET				U305	U305	U305	U305	U305	L305
342				DIE SET							S342	P342	L342
344				DIE SET									L344
345				DIE SET									L345
346 ⑦			1 CRIMP	DIE SET	GRAY		X6CART	U6CABT	U6CABT	U6CABT	U6CABT	U6CABT	
348			1 CRIMP	DIE SET	PINK		X2CART	U2CABT	U2CABT	U2CABT	U2CABT	U2CABT	
350				DIE SET				U350	U350	U350	U350	U350	L350
352				DIE SET							S352	P352	L352
373				DIE SET				U373	U373	U373	U373	U373	

**PRESENT INSTALLATION TOOL INDEX (continued)**

DIE		DIELESS TOOLS		INSTALLATION TOOLING USING DIES									
GROOVE		MECH.	HYD.	DIE INFORMATION		MECHANICAL		HYDRAULIC					
BURNDY	E EI	MR, MY	Y644	TYPE	COLOR	MD6	OUR840	Y35 ①	Y39	Y750 ①	Y45 ②	Y46 ③	Y60 Ser.
374		MY29-3		DIE SET	BLUE		X8CART	U8CABT	U8CABT	U8CABT	U8CABT	U8CABT	
375		MY29-3	1 CRIMP	DIE SET	GREEN		X4CART	U4CABT	U4CABT	U4CABT	U4CABT	U4CABT	
376 314				DIE SET									L314
400				DIE SET	PURPLE			U38RT	U38RT	U38RT	U38RT	U38RT	
403				DIE SET				U403	U403	U403	U403	U403	
419				DIE SET							S419	P419	L419
422				DIE SET									L422
426 317				DIE SET				U317	U317	U317	U317	U317	
459 166				DIE SET				U166/459	U166/459	U166/459	U166/459	U166/459	
467		MY29-3	1 CRIMP	DIE SET	RUBY		X27ART	U27ART	U27ART	U27ART	U27ART	U27ART	
				NEST								P30D	
				INDENTOR								P34PR5	
468				DIE SET			U468	U468	U468	U468	U468		
469				DIE SET						S469	P469	L469	
470			1 CRIMP	DIE SET	BLUE			U30ART	U30ART	U30ART	U30ART	U30ART	L30ART
				NEST								P34D	
				INDENTOR								P48PR1	
471		MY29-3	1 CRIMP	DIE SET	GOLD		X1CART	U1CART	U1CART	U1CART	U1CART	U1CART	
				NEST									
				INDENTOR									
472			1 CRIMP	DIE SET	GREEN			U32ART	U32ART	U32ART	U32ART	U32ART	L32ART
				NEST								P35D	
				INDENTOR								P48PR1	
473			1 CRIMP	DIE SET	BLACK			U36ART	U36ART	U36ART	U36ART	U36ART	L36ART
				NEST								P44D	
				INDENTOR								P48PR1	
474			1 CRIMP	DIE SET	GOLD					S40ART	P40ART	L40ART	
				NEST									
				INDENTOR									
478			1 CRIMP	DIE SET	BLUE								L46ART
				NEST									
				INDENTOR									
479				DIE SET	RED							L48ART	
490 547				DIE SET				U490	U490	U490	U490	U490	L490
495				DIE SET									L495
505 163				DIE SET		W163		U163	U163	U163	U163	U163	L163
511		MY29-3		NEST INDENTOR									
512		MY29-3		NEST INDENTOR									
513		MY29-3		NEST INDENTOR									
514		MY29-3		NEST INDENTOR									

PRESENT INSTALLATION TOOL INDEX (continued)

DIE		DIELESS TOOLS		INSTALLATION TOOLING USING DIES									
GROOVE		MECH.	HYD.	DIE INFORMATION		MECHANICAL		HYDRAULIC					
BURNDY	EEl	MR, MY	Y644	TYPE	COLOR	MD6	OUR840	Y35 ①	Y39	Y750 ①	Y45 ②	Y46 ③	Y60 Ser.
515		MY29-3		NEST INDENTOR									
516		MY29-3		NEST INDENTOR									
517		MY29-3		NEST INDENTOR									
518		MY29-3		NEST INDENTOR									
519		MY29-3		NEST INDENTOR									
520		MY29-3		NEST INDENTOR									
538 326				DIE SET				U33RT	U33RT	U33RT	U33RT	U33RT	
547 490				DIE SET				U490	U490	U490	U490	U490	L490
552				DIE SET				U552	U552	U552	U552	U552	
568 167 207 211 256				DIE SET		W167		U167/ U568	U167/ U568	U167/ U568	U167/ U568	U167/ U568	
575				DIE SET									L575
576				DIE SET									L576
578 292				DIE SET							S292	P292	L292
579				DIE SET							S579	P579	L579
587				DIE SET									L47ART
607				DIE SET				U607	U607	U607	U607	U607	
608				DIE SET				U608	U608	U608	U608	U608	608
609				DIE SET				U609	U609	U609	U609	U609	
627				DIE SET									L627
642				DIE SET				U642	U642	U642	U642	U642	L642
643				DIE SET				U643	U643	U643	U643	U643	
647Ⓞ				DIE SET									L45ART
648				DIE SET									L648
654				DIE SET	PURPLE			U654	U654	U654	U654	U654	L654
655	13A			DIE SET				U655	U655	U655	U655	U655	
658				DIE SET				U658	U658	U658	U658	U658	
659				DIE SET		W659		U659	U659	U659	U659	U659	
660				DIE SET		W660	X-660	U660	U660	U660	U660	U660	
667				DIE SET									L667
668				DIE SET				U668	U668	U668	U668	U668	
676				DIE SET				U676	U676	U676	U676	U676	
677				DIE SET				U677	U677	U677	U677	U677	L677
678				DIE SET				U678	U678	U678	U678	U678	
679				DIE SET				U679	U679	U679	U679	U679	
684				DIE SET									L684
687				DIE SET		W687	X-687						
690	1S			DIE SET		W690		U690	U690	U690	U690	U690	
691	2S			DIE SET		W691		U691	U691	U691	U691	U691	

**PRESENT INSTALLATION TOOL INDEX (continued)**

DIE		DIELESS TOOLS		INSTALLATION TOOLING USING DIES									
GROOVE		MECH.	HYD.	DIE INFORMATION		MECHANICAL		HYDRAULIC					
BURNDY	E EI	MR, MY	Y644	TYPE	COLOR	MD6	OUR840	Y35 ①	Y39	Y750 ①	Y45 ②	Y46 ③	Y60 Ser.
692	4S			DIE SET		W692		U692	U692	U692	U692	U692	
693	6A			DIE SET		W693		U693	U693	U693	U693	U693	
694	10A			DIE SET		W694		U694	U694	U694	U694	U694	
702				DIE SET		W702							
705				DIE SET				U705	U705	U705	U705	U705	
717				DIE SET							S717	P717	L717/ L717W
718				DIE SET									L718
719				DIE SET							S719	P719	L719/ L719W
720				DIE SET							S720	P720	L720/ L720W
721				DIE SET									L721
722				DIE SET							S722	P722	L722/ L722W
723				DIE SET									L723
724				DIE SET							S724	P724	L724/ L724W
725				DIE SET							S725	P725	L725/ L725W
726				DIE SET									L726
727				DIE SET									L727/ L727W
728				DIE SET									L728/ L728W
729				DIE SET									L729/ L729W
735				DIE SET									L735/ L735W
740				DIE SET									L740
786				DIE SET				U786	U786	U786	U786	U786	
788				DIE SET				U788	U788	U788	U788	U788	
789				DIE SET									L789
936			1 CRIMP	DIE SET	YELLOW			U39ART-2	U39ART-2	U39ART-2	U39ART-2	U39ART-2	L39ART-2
997				DIE SET	ORANGE			U997	U997	U997	U997	U997	
998				DIE SET						PU998	S998	P998	
999				DIE SET							S999	P999	
1011				DIE SET						U1011	S1011	P1011	
1012				DIE SET							S1012		
1013		MY29-11		NEST				UV8L	UV8L	UV8L	UV8L	UV8L	
				INDENTOR				Y34PL	Y34PL	Y34PL	Y34PL	Y34PL	
1014		MY29-11		NEST				U6CD1	U6CD1	U6CD1	U6CD1	U6CD1	
				INDENTOR				Y34PR	Y34PR	Y34PR	Y34PR	Y34PR	
1015		MY29-11		NEST				U4CD1	U4CD1	U4CD1	U4CD1	U4CD1	
				INDENTOR				Y34PR	Y34PR	Y34PR	Y34PR	Y34PR	
1016		MY29-11		NEST				U3CD1	U3CD1	U3CD1	U3CD1	U3CD1	
				INDENTOR				Y34PR	Y34PR	Y34PR	Y34PR	Y34PR	

**PRESENT INSTALLATION TOOL INDEX (continued)**

DIE		DIELESS TOOLS		INSTALLATION TOOLING USING DIES										
GROOVE		MECH.	HYD.	DIE INFORMATION		MECHANICAL		HYDRAULIC						
BURNDY	EEI	MR, MY	Y644	TYPE	COLOR	MD6	OUR840	Y35 ①	Y39	Y750 ①	Y45 ②	Y46 ③	Y60 Ser.	
1017		MY29-11		NEST				U2CD1	U2CD1	U2CD1	U2CD1	U2CD1		
				INDENTOR				Y34PR	Y34PR	Y34PR	Y34PR	Y34PR		
1018		MY29-11		NEST				U1CD1	U1CD1	U1CD1	U1CD1	U1CD1		
				INDENTOR				Y34PR	Y34PR	Y34PR	Y34PR	Y34PR		
1019		MY29-11		NEST				U25D1	U25D1	U25D1	U25D1	U25D1		
				INDENTOR				Y34PR2	Y34PR2	Y34PR2	Y34PR2	Y34PR2		
1020		MY29-11		NEST				U26D1	U26D1	U26D1	U26D1	U26D1		
				INDENTOR				Y34PR2	Y34PR2	Y34PR2	Y34PR2	Y34PR2		
1021		MY29-11		NEST				U27D1	U27D1	U27D1	U27D1	U27D1		
				INDENTOR				Y34PR2	Y34PR2	Y34PR2	Y34PR2	Y34PR2		
1022		MY29-11		NEST				U28D1	U28D1	U28D1	U28D1	U28D1		
				INDENTOR				Y34PR2	Y34PR2	Y34PR2	Y34PR2	Y34PR2		
1023		MY29-11		NEST				U29D1	U29D1	U29D1	U29D1	U29D1		
				INDENTOR				Y34PR2	Y34PR2	Y34PR2	Y34PR2	Y34PR2		
1024				NEST				U30D1	U30D1	U30D1	U30D1	U30D1		
				INDENTOR				Y34PR2	Y34PR2	Y34PR2	Y34PR2	Y34PR2		
1025				NEST				U31D1	U31D1	U31D1	U31D1	U31D1		
				INDENTOR				Y34PR2	Y34PR2	Y34PR2	Y34PR2	Y34PR2		
1026				NEST				U32D1	U32D1	U32D1	U32D1	U32D1		
				INDENTOR				Y34PR2	Y34PR2	Y34PR2	Y34PR2	Y34PR2		
1027				NEST				U34D1	U34D1	U34D1	U34D1	U34D1		
				INDENTOR				Y34PR2	Y34PR2	Y34PR2	Y34PR2	Y34PR2		
1028				NEST								P36D		
				INDENTOR										Y48PR1
1029				NEST									P38D	
				INDENTOR										P48PR1
1030				NEST									P39D	
				INDENTOR										P48PR1
1031				NEST									P40D	
				INDENTOR										P48PR1
1032				NEST									P44D	
				INDENTOR										P48PR1
1102				DIE SET	WHITE								P1102	
1103				DIE SET	BLUE									P1103
1104				DIE SET	BROWN					U1104				P1104
1105				DIE SET						U1105				P1105
2000				NEST				U27B	U27B	U27B	U27B			
				INDENTOR				Y34PR15	Y34PR15	Y34PR15	Y34PR15			

① Cat. No. Y35P3 Adaptor is required to use "Y34PR" type indentors with "U" type nest dies in Y35 and Y750 series.

② Cat. No. PT6515 Adaptor is required to use "U" type dies in Y45 series.

③ Cat. No. PUADP-1 Adaptor is required to use "U" type dies in Y46 series.

④ The MD6-6R2 ratchet tool is required on these sizes. The standard MD6 or MD6R ratchet tools will not work.

⑤ Also pneumatic version Y29NC.

⑥ Die 302 recommended for 1.84 O.D. barrel.

⑦ Hexagonal crimp



**ALPHA-NUMERIC INDEX BY CATALOG NUMBER**

Catalog Number	Page Number
122EMT	117
122IMC	117
122PVC	117
122RIG	117
12TONP1	63
23CRT	68
ALFLUIDGAL	94
ALFLUIDQT	94
B12E	116
B1CD	39
B1E34R	116
B25D	39
B26D	39
B27D	39
B28D	39
B29D	39
B2CD	39
B30D	39
B31D	39
B32D	39
B34E12R	116
B4CD	39
BAGCNV5X9X24	78
BAT18V	71
BAT18VLI	9-12, 14-20, 70, 72-75
BCC1000CUAL	76
BCCBAT12V	76
BCCCASE	76
BCCCHGR	76
BCH1211	115
BCM5	115
BCT/PATDCCHGR	71
BEB122	117
BEB122EMT	117
BEB122PVC	117
BEB122RIG	117
BECBSD	62
BECNVSD	62
BH864	115
BHA12E	116
BHA1E34R	116

Catalog Number	Page Number
BHA34E12R	116
BK88001	113
BK88004	113
BK88007	113
BK88008	113
BK88020	113-114
BKC3540	115
BKD1000B	113-115
BKD1250B	113-115
BKD1500B	113-115
BKD2000B	113-115
BKD2500	113, 115
BKD3000	113, 115
BKD3500	113, 115
BKD4000	113, 115
BKD500B	113-115
BKD750B	113, 115
BKLP2	114
BKLP2K1	114
BKLP6	114
BKLP6K1	114
BKOF540	115
BKOH2540	113
BKOH520A	115
BKOH540A	115
BKOM152	113
BKOM50125	113
BKOR14	113
BKOR152	113
BKOR50	113
BKOR520	113
BKOR75125	113
BKOS520	114
BKOS5290	114
BKOW520	113
BKP1000B	113-115
BKP1250B	113-115
BKP1500B	114, 115
BKP2000B	113-115
BKP2500	113, 115
BKP3000	113, 115
BKP3500	113, 115

Catalog Number	Page Number
BKP4000	113, 115
BKP500B	113-115
BKP750B	113-115
BKPR7520	114
BKPR7540	115
BKPS50	114, 115
BKS752B	113
BKSA50	114
BKSB50B	113
BKW52	113
BMY-BCH-MT	54
BP10PADKIT	90
BPF65	115
BPH20	115
BSC2H	118
BSC2H1C2DEBP	118
BSC2H2A1B1FEBP	118
BSC2H2C1DEBP	118
BSC2H3A2B	118
BSC2H5A	118
BSC2H5B	118
BSC2L	119
BSC2L1C2DEBP	119
BSC2L2C1DEBP	119
BSC2L3A2B	119
BSC2L5A	119
BSC2L5B	119
BSCWS40	118-120
BSCWS80	118-120
BTW150750	100
BTW1575F12	100
BTW30150	100
CASEWDIES	68, 95
CUT200BLMVBL	70
CUT200BLSTA	70
D3CL	65
D6CL	65
DEV1L	40
DEV25L	40
DEV26L	40
DEV2L	40
DEV4L	40

**ALPHA-NUMERIC INDEX BY CATALOG NUMBER (continued)**

Catalog Number	Page Number
DEV6L	40
DEV8L	40
DV1L	40, 65
DV25L	40, 65
DV26L	40, 65
DV2CL	65
DV2L	40
DV4L	40, 65
DV6L	40, 65
DV8L	65
DV8L-1	40
EP10	88
EP10-1HP	88
EP10-1HP-2	88
EP10-2	88
EP6	88
EPAC10	89
EPAC16	89
EPB	118, 119
EPP10	87
EPP6	87
EPPCASE-1	87
FORCEGAUGE12-15	21, 98
FP10	90
FP6	90
GP10	91
H12E	116
H1E34R	116
H3412R	116
HBR40	106
HBR66	106
HCCACSR	71, 79
HCCQUAL	71, 79
HCCGUY	71, 79
HCCSOL	71, 79
HHS-O/C-4-B13	109
HHS-O/C-5-B13	109
HHS-O/C-B13	109
HHS-O/C-B16	109
HHS-O/C-B20	109
HIW12SOCSET	112
HIW71612TGKIT	112

Catalog Number	Page Number
HIW716ENF	103
HIW716ENFTG	103
HIW716ENFTGKIT	103
HIW716MAG	104
HIW716MAGKIT1	104
HIW716MAGKIT2	104
HIW716MAGKIT3	104
HIW716MAGKIT4	104
HIW716MAGKIT5	104
HOSE2	107
HOSE325	107
HOSE350	107
HP10	90
HP2CAMLOCKHOSESET	107
HP2HV	107
HP3	107
HP6	90
HPP18	111
HPP18-2	111
HPP5	111
HPS1371LW	110
HPS1383LW	110
HPT59R1	108
HPT60R1	108
HPT71R1	108
HPT72R1	108
HPT83R1	108
HPT84R1	108
HPT96R1	108
HTP3	107
HYFLUIDGAL	97
HYFLUIDQT	97
J1022NC1	46, 61
J1022NC2	46, 61
J1022NC3	46, 61
J1022NC4	46, 61
J1022NC5	46, 61
J4CNC	61
J6CNC	61
J8CNC	61
KWADP	57
LPC12C	112

Catalog Number	Page Number
LPC38S	112
LPHT3CHISEL11418	112
LPHTADPMM71612	104, 112
LPHTADPMMOP66	103, 104, 112
LPHTADPSMFOP66	104, 105
LPHTASPHALTCUT118	112
LPHTBIT111612HC	102
LPHTBIT111612SC	102
LPHTBIT111618	102
LPHTBIT111618D	102
LPHTBIT111618HC	102
LPHTBIT111618R	102
LPHTBIT111624D	102
LPHTBIT111624R	102
LPHTBIT11812HC	102
LPHTBIT11824D	102
LPHTBIT11824R	102
LPHTBIT1218	102
LPHTBIT131612HC	102
LPHTBIT131612SC	102
LPHTBIT131618	102
LPHTBIT131618D	102
LPHTBIT131618HC	102
LPHTBIT131618R	102
LPHTBIT131618SC	102
LPHTBIT131624	102
LPHTBIT131624D	102
LPHTBIT131624R	102
LPHTBIT151618	102
LPHTBIT151618D	102
LPHTBIT151618R	102
LPHTBIT151624D	102
LPHTBIT151624R	102
LPHTBIT3418D	102
LPHTBIT3418R	102
LPHTBIT3424D	102
LPHTBIT5818D	102
LPHTBIT5818R	102
LPHTBIT5824D	102
LPHTBIT7818D	102
LPHTBIT91612HC	102
LPHTBIT91618R	102

**ALPHA-NUMERIC INDEX BY CATALOG NUMBER (continued)**

Catalog Number	Page Number
LPHTBIT9168R	102
LPHTCLAYSPADE118	112
LPHTDRIPBODY66	112
LPHTDRIPBODY88	112
LPHTDRIPNOSE66	112
LPHTDRIPNOSE88	112
LPHTGRDVR11458	112
LPHTHOSNCR666610	105, 112
LPHTHOSNCR666610OP	105, 112
LPHTHOSNCR66668	103-105, 112
LPHTHOSNCR66668OP	105
LPHTHOSNCR6668OP	112
LPHTHTMABODY66	104, 150
LPHTHTMADUSTCAPF	112
LPHTHTMADUSTCAPM	112
LPHTHTMANOSE66	103-105
LPHTMOILPT118	112
LPHTNARCHISEL11814	112
LPHTSOC121	112
LPHTSOC121116	112
LPHTSOC12112	112
LPHTSOC12114	112
LPHTSOC12118	112
LPHTSOC1212	112
LPHTSOC121316	112
LPHTSOC12138	112
LPHTSOC121716	112
LPHTSOC1234	112
LPHTSOC1258	112
LPHTSOC1278	112
LPHTSOC12916	112
LPHY750CXT	105
LPHY750XT	105
LPTHHTMABODY66	103
LPWHPKITD	108
M8ND	52
MAGHOLSTER	104
MCC1000	82
MCC1000BLADESET	82
MCC600	82
MCC600BLADESET	82
MD6	57

Catalog Number	Page Number
MD6-12	57
MD6-14	57
MD6-37	57
MD6-38	57
MD6-4	57
MD6-6	57
MD6-8	57
MD6-CP1	96
MD6-K	57
MD7	58
MD7-34	59
MD7-34-KIT1	59
MD7-34R	59
MD7-34R-C	59
MD7-34R-KIT1	59
MD7-6	58
MD7-8	58
MINBAG	79
MR15	48
MR15DIESETD1	48
MR18	48
MR18DIESETD1	48
MR20	48
MR20DIESETD1	48
MR4C	49
MR8-1A	45
MR8-33S-1	45
MR8-33T-1	45
MR8-9Q	45
MR8-G96	45
MR8-G98	45
MRC840	53
MRC840AL	53
MRE10-22B	47
MRE10-22NV	47
MTB	118, 119
MTX	118, 119
MY28	54
MY28-4	54
MY28-6	54
MY29-11	54
MY29-11C	54

Catalog Number	Page Number
MY29-3	54
MY29-3C	54
MY29UNIVERSALKIT	54
OEM840NCP	60
OH25	55
OUR840	56
OUR840-WC	56
P15K	9, 10, 30, 31
PAT18VLI	13
PAT46CLWS-18V	9
PAT46CLWS-LI	9
PAT46LW-18V	10
PAT46LW-LI	10
PAT46LWS-18V	9
PAT46LWS-LI	9
PAT4PC834-18V	14
PAT4PC834-LI	14
PAT500J6K-LI	16
PAT500SJ66-LI	16
PAT500SJ68-LI	16
PAT500SJ6-LI	16
PAT500SJ-LI	16
PAT600-LI	15
PAT644-LI	12
PAT644XT-18V	12
PAT750C-LI	11
PAT750CXT-18V	11
PAT750K-LI	11
PAT750-LI	11
PAT750XT-18V	11
PAT81KFT-18V	13
PAT81KFT-LI	13
PATCHGR18V	71
PATCHGR250V	71
PATCHGR-LI	9-20, 70, 72-75
PATCHGR-LIDC	9-20, 70, 72-75
PATCUT129ACSR-18V	72
PATCUT129ACSR-18V250V	72
PATCUT129ACSR-18VDC	72
PATCUT129-LI	72
PATCUT129-LIDC	72
PATCUT2156-18V	70

**ALPHA-NUMERIC INDEX BY CATALOG NUMBER (continued)**

Catalog Number	Page Number
PATCUT2156-18V250V	70
PATCUT2156-18VDC	70
PATCUT2156-LI	70
PATCUT2156-LIDC	70
PATCUT245CUAL-18V	73
PATCUT245CUAL-18V250V	73
PATCUT245CUAL-18VDC	73
PATCUT245-LI	73
PATCUT245-LIDC	73
PATHCC10-18V	71
PATHCC10-ACSR-18V	71
PATHCC10C-18V	71
PATHCC10C-ACSR-18V	71
PATHCC10C-CUAL-18V	71
PATHCC10C-GUY-18V	71
PATHCC10C-SOL-18V	71
PATHCC10-CUAL-18V	71
PATHCC10-GUY-18V	71
PATHCC10-SOL-18V	71
PATJAWSCUT	16, 17, 74, 75
PATJAWSMD6	16, 17, 74, 75
PATJAWSMD6-6	16, 17, 74, 75
PATJAWSMD6-8	16, 17, 74, 75
PATJAWSMD6K	16, 17, 74, 75
PATMD1022-LI	20
PATMD6-14V	17
PATMD6-6-14V	17
PATMD6-6JC	16-19, 74, 75
PATMD6-6-LI	17
PATMD66LICUTKIT1	19
PATMD66LIWCJ	18
PATMD6-8-14V	17
PATMD6-8-LI	17
PATMD68LICUTKIT1	19
PATMD68LIWCJ	18
PATMD6JC	16-19, 74, 75
PATMD6-K-14V	17
PATMD6-KJC	16-19, 74, 75
PATMD6-K-LI	17
PATMD6KLIWCJ	19
PATMD6KLIWCJ	18
PATMD6-LI	17

Catalog Number	Page Number
PATMD6LICUTKIT1	19
PATMD6LIWCJ	18
PATMDCUT14V	74
PATMDCUT14V250V	74
PATMDCUT14VDC	74
PATMDCUT48L-LI	75
PATMDCUT48L-NMH	75
PATMDCUT60L-LI	75
PATMDCUT60L-NMH	75
PATMDCUT72L-LI	75
PATMDCUT72L-NMH	75
PATMDCUTACSRKIT	74, 75
PATMDCUT-LI	74
PATMDCUT-LIDC	74
PATMDLICUTKIT1	19
PG121-1	49
PG125-1	49
PG133-1	49
PG395-1	44
PG396-1	44
PG397-1	44
PG398-1	44
PG-403-1R	20, 47
PG-403-2R	20, 47
PG-406-1	20, 47
PG-407-1	20, 47
PG-408-1	20, 47
PT10024162	77
PT10037384	72, 77, 80
PT10037388	72, 77, 80
PT10038657	73, 81
PT10040663	73, 81
PT10043890	80
PT10050733	25, 26
PT10054094	33, 37, 38, 81
PT10074020	16-19, 74, 75
PT10128	79, 97
PT11018	94
PT208620	10-15, 70, 72, 73
PT212851	27
PT29074-1	94

Catalog Number	Page Number
PT29092	94
PT29214-1	94
PT29279-2	98
PT29291	21, 33, 66, 67, 97
PT29360	97
PT29402-1	33, 97
PT2972	23, 97
PT29900-10	63, 64, 92
PT29900-15	92
PT29900-25	92
PT29901-10	92
PT29901-15	92
PT29901-25	92
PT29902-10	92
PT29902-15	92
PT29902-25	92
PT4583	56
PT4925	59, 96
PT4931-1	96
PT4952-1	59, 96
PT4983	55
PT50024605	60
PT50024683	60
PT50024685	60
PT50025151	19
PT6515	32
PT6545	32, 97
PT6733	96
PT6744	96
PT76	93
PT8504	55
PT91	93
PT93	94
PT94	94
PU998	67
PUADP-1	9, 10, 30, 31
R17A	118-120
R17C	118-120
R22B	118-120
R24F	118-120
R25D	118-120

**ALPHA-NUMERIC INDEX BY CATALOG NUMBER (continued)**

Catalog Number	Page Number
RCC1000	83
RCC336	84
RCC556	84
RCC6003	83
RCC750HD	83
RCC954ACSR1K	84
RHCC10	79
RHCC10-ACSR	79
RHCC10C	79
RHCC10C-ACSR	79
RHCC10C-CUAL	79
RHCC10C-GUY	79
RHCC10C-SOL	79
RHCC10-CUAL	79
RHCC10-GUY	79
RHCC10-SOL	79
RHCC129ACSR	80
RHCC245CUAL	81
RHCC4CUAL	78
RHCC4CUALBLD	78
RHCC4CUALGDEBLD	78
RHCCHSA	80, 81
RK194-2	99
RP50RP02	76
RP50RP03	76
RPC701302	83
RPC701402	83
RPC705501	84
RPC705601	84
RPC902101	84
RPC902201	84
RWRC516	85
RWRC916	85
SD10NCP1CH	62
SD10NCP1LP1	62
TK-KD	108
TK-SQ	108
TOOLBAGMDLI	17, 18
U1011	67
U1104	67
U1105	67
U1CART	66, 67

Catalog Number	Page Number
U1CRT-1	66, 67
U1CRT-1W	66, 67
U25ART	66, 67
U25RT	60, 66, 67
U25RTW	66, 67
U26ART	66, 67
U26RT	60, 66, 67
U26RTW	66, 67
U27ART	66, 67
U27RT	60, 66, 67
U27RTW	66, 67
U28ART	66, 67
U28RT	60, 66, 67
U28RTW	66, 67
U29ART	66, 67
U29RT	66, 67
U2CABT	66, 67
U2CRT	60, 66, 67
U2CRTW	66, 67
U30ART	66, 67
U30RT	66, 67
U31ART	66, 67
U31RT	66, 67
U32ART	66, 67
U32RT	66, 67
U34ART	66, 67
U34RT	66, 67
U36ART	66, 67
U36RT	66, 67
U38XRT	66
U39ART-2	66, 67
U39RT	66, 67
U3CRTW	66
U43CRT	66
U44XRT	66
U4CABT	66, 67
U4CRT	60, 66, 67
U4CRTW	66, 67
U5CRT	66, 67
U5CRTW	66, 67
U6CABT	66, 67
U6CRT	60

Catalog Number	Page Number
U8CABT	66
U8CRT	60, 66
U8CRTW	66, 67
U97	67
UC	67
UDIEKITAL	63, 67
UDIEKITCU	63, 67
UDIEKITCUW	67
UDIEKITHYGRD	67
UM25N	60
UM26N	60
UM27N	60
UM28N	60
UM2CN	60
UM4CN	60
UM6CN	60
UM8CN	60
UMA	60
UMB	60
UMC	60
UO	67
W161	68, 69
W162	68, 69
W163	68, 69
W166	68, 69
W1CRT-1	68, 69
W1CVT	68
W239	68, 69
W241	68, 69
W245	68, 69
W249	68, 69
W25RT	60, 68, 69
W25VT	68
W26RT	60, 68, 69
W26VT	68
W27RT	60, 68, 69
W27VT	68
W28K	16-19, 56, 95
W28RT	60, 68, 69
W28VT	68
W29RT	68, 69
W29VT	68

**ALPHA-NUMERIC INDEX BY CATALOG NUMBER (continued)**

Catalog Number	Page Number
W2CRT	60, 68, 69
W2CVT	68
W30RT	68
W30VT	68
W31ART	68, 69
W31RT	68, 69
W31VT	68
W32RT	68
W32VT	68
W33RT	68
W33VT	68
W34RT	68, 69
W34VT	68
W36RT	68
W3CRT	68
W4CRT	60, 68, 69
W4CVT	68
W5CRT	68, 69
W5CVT	68
W660	68, 69
W-687	95
W6CRT	60
W-702	95
W8CRT	60, 68, 69
W8CVT	68
W-BG	57, 58, 95
WDA8300	27
WDC4500	27
WDIEKITAL	69
WDIETREE	15-19, 57-59, 68, 95
WDITKITCU	69
WIREMIKE	99
WIREMIKE-D	99
W-O	57, 58
X1CART	56
X1CRT	56
X25ART	56
X25RT	56
X26ART	56
X26RT	56
X27ART	56

Catalog Number	Page Number
X27RT	56
X28ART	56
X28RT	56
X29RT	56
X2CART	56
X2CRT	56
X4CART	56
X4CRT	56
X5CRT	56
X6CART	56
X8CART	56, 68, 69
X8CRT	56
XOH25	56
Y10-22	41
Y10AC9	86
Y10AC9OEM	86
Y10D	41
Y10MRS A1	46
Y122CMR	51
Y122CMRKIT	51
Y1MRKIT	50
Y1MRTC	50
Y1MRTCKIT	50
Y29BH	40
Y29NC	65
Y29PL	40, 65
Y29PLE	40
Y29PLE-1	40
Y29PR	65
Y2CNC	61
Y34BH	39
Y34BH-1	39
Y34PA	39
Y34PR	39
Y34PR-1	39
Y34PR-11	39
Y35	22
Y35/Y39REPKITA	97
Y35-2	22
Y35BH	34
Y35BH-4	34
Y35H	34

Catalog Number	Page Number
Y39	23
Y39BH	35
Y45	32
Y46CLWSBH	30
Y46CLWSBHF	30
Y46LWBH	31
Y46LWBHF	31
Y46LWSBH	30
Y46LWSBHF	30
Y46OEM11T	64
Y46OEM11TKIT1	64
Y46OEM12T	63
Y46OEM12TKIT	63
Y46OEM12TKIT1	63
Y46OEM12TKIT1FC	63
Y46OEM12TKITFC	63
Y46OEMGUARD	63, 64
Y46OEMLOCATOR	63, 64
Y4PC834	26
Y4PC834MBH	38
Y500CT-HS	27
Y60BHU	29
Y60BHUD	29
Y60LW	28
Y60LWCASE	28
Y60LWSTAND	28
Y644HSCASE	24
Y644HSXT	24
Y644MBH	36
Y6NCP1	61
Y6NCP1BMNT	61, 62
Y6NCP1CH	61
Y6NCP1FTSW	61, 62
Y6NCP1SD	62
Y750BHXT	33
Y750CBHXT	33
Y750CHSXT	21
Y750HSCASE	21
Y750HSXT	21
Y7AC9	64
Y81KFT	25
Y81KFTMBH	37

**ALPHA-NUMERIC INDEX BY CATALOG NUMBER (continued)**

<b>Catalog Number</b>	<b>Page Number</b>
Y8AC9	63
Y8MRB-1	44
YAC-CASE	86
YACFC	63
YAC-FC	86
YCUT129ACSR	77
YF0401TOOL	43
YF0801TOOL	43
YF1/03/0TOOL	43
YF1006TOOL	43
YF2/0250TOOL	43
YF22-10FL	42
YF2210TOOL	43
YF2214TOOL	43
YF2610TOOL	43
YF3206TOOL	43
YN6NCP1	62
YNCP1SD	61

INSTALLATION TOOLING SYSTEM														
Conductor		LUGS & SPLICES One & Two HOLE				TAPS Thin-Wall C-taps Run=Tap, AWG only			TAPS Heavy Duty C-Taps Run=Tap			TAPS H-Taps Run=Tap		
		Die	Color	Index	T&B Index Code (Flex)	Die	Color	Index	Die	Color	Index	Die	Color	Index
#8/#6 sol	#8	W8CVT U8CRT	RED	49	21	W4CVT	GRAY	8	U240	RED	240	U11T-1	GREEN	11
#6	#6	W5CVT U5CRT	BLUE	7	24	W2CVT	BROWN	10	UC	BROWN	C	UBGRT	ORANGE	BG
#4	#4	W4CVT U4CRT	GRAY	8	29	W25VT	PINK	12	UC	BROWN	C	UC	BROWN	C
#3/#2 sol		W3CRT U3CRT	WHITE	9		W26VT	BLACK	13	UC	BROWN	C	UC	BROWN	C
#2	#2	W2CVT U2CRT	BROWN	10	33	W27VT	ORANGE	14	UC	BROWN	C	UC	BROWN	C
#1	#1	W1CVT U1CRT-1	GREEN	11		W28VT	PURPLE	15	U997	ORANGE	997	U654	PURPLE	654
1/0	1/0	W25VT U25RT	PINK	12	42 (45)	W29VT	YELLOW	16	U997	ORANGE	997	U654	PURPLE	654
2/0	2/0	W26VT U26RT	BLACK	13	45 (50)		REFER TO CATALOG		U997	ORANGE	997	U654	PURPLE	654
3/0	3/0	W27VT U27RT	ORANGE	14					U997	ORANGE	997	U654	PURPLE	654
4/0	4/0	W28VT U28RT	PURPLE	15	54 (62)	-	-	-	U997	ORANGE	997	U654	PURPLE	654
250	4/0/ 250 class G & H	W29VT U29RT	YELLOW	16		-	-	-	U997	ORANGE	997	U654	PURPLE	654
300	252/ 250 class I, K & M	W30VT U30RT	WHITE	17		-	-	-	U1104	BROWN	1104	U1104	BROWN	1104
350	313	W31VT U31RT	RED	18	71	-	-	-	U1104	BROWN	1104	U1104	BROWN	1104
	350/ 373	W32VT U32RT	BLUE	19		-	-	-	U1104	BROWN	1104	U1104	BROWN	1104
500	444	W34VT U34RT	BROWN	20	87	-	-	-	U1104	BROWN	1104	U1104	BROWN	1104
	500/ 535	U38XRT	PINK	L99		-	-	-	P1103	BLUE	1103	PYFR	YELLOW	KR
600		U38RT	GREEN	22	(99)	-	-	-	P1103	BLUE	1103	PYFR	YELLOW	KR
700		U38RT	PINK	400		-	-	-	P1103	BLUE	1103	PYFR	YELLOW	KR
750	646	U39RT	BLACK	24	106	-	-	-	P1103	BLUE	1103	PYFR	YELLOW	KR
	750/ 777	U44XRT P44XRT-1	YELLOW	L115										
800		P40RT	ORANGE	25	(115)	-	-	-	P1102	WHITE	1102	PYFR	YELLOW	KR
1000		P44RT	WHITE	27		-	-	-	P1102	WHITE	1102	PYFR	YELLOW	KR



## Trust the BURNDY® Engineered System

The BURNDY® Engineered System of coordinating dies, connectors and tools are designed to work together and engineered to meet stringent, accepted quality standards.



[www.burndy.com](http://www.burndy.com) | 1-800-346-4175

### Customer Service Department

7 Aviation Park Drive  
Londonderry, NH 03053  
1-800-346-4175  
1-603-647-5299 (International)

### Canada

1-800-361-6975 (Quebec)  
1-800-387-6487 (All other provinces)

### Mexico

011-52-722-265-4400

### Brazil

011-55-11-5515-7225

### Tool Service Center

Littleton Industrial Park  
Littleton, NH 03561  
1-800-426-8720



Connecting Power to Your World™

